



City Council Meeting Agenda
Monday, August 5, 2024 – 6:30 p.m.
City Hall, 200 South Osage, Sedalia MO

MAYOR: ANDREW L. DAWSON

MAYOR PRO-TEM: TINA BOGGESS

- A. CALL TO ORDER** – Andrew L. Dawson – Council Chambers
- B. PRAYER & PLEDGE OF ALLEGIANCE**
- C. ROLL CALL**
- D. SERVICE AWARDS**
1. Tammy Lewis – PW Program Specialist – Street – 40 years of service
 2. Shania Fox – Police Officer – Police – 5 years of service
 3. Wayne Humphrey – Filtration Plant Op II – Water – 5 years of service
- E. RETIREMENT AWARDS**
1. John Simmons – Director – Community Development – 18 Years of service
 2. George Stevens – Equipment Operator II – Sanitation – 34 Years 2 ¾ Months of service
- F. SPECIAL AWARDS**
1. Sedalia Fire Department – Lieutenant Pinnings
 - Alex Razumovsky
 - Chris Maggert
 - Colby Snapp
 - Jeremy Pepin
 - Matt Moulton
 - Nathaniel Nevels
- I. APPROVAL OF PREVIOUS SESSION MINUTES**
- A. Council Meeting – July 15, 2024
- II. REPORT OF SPECIAL BOARDS, COMMISSIONS AND COMMITTEES** - None
- III. ROLL CALL OF STANDING COMMITTEES**
- A. FINANCE/ADMINISTRATION** – Chairwoman Tina Boggess; Vice Chairman Tom Oldham
1. Fentanyl Ordinance
Council Discussion led by Chairwoman Boggess
 - Call for Ordinance of the City of Sedalia Missouri to prohibit unlawful use of drug paraphernalia with Fentanyl – Mayor Dawson
 2. Budget Amendment – Embassy – \$50,000.00
Council Discussion led by Chairwoman Boggess
 - Call for Resolution of the City Council of the City of Sedalia, Missouri, stating facts and reasons for the necessity to amend and increase the City’s Annual Budget for Fiscal Year 2025 – Mayor Dawson
 - Call for Ordinance Amending the Budget for the Fiscal Year 2024-2025 regarding Embassy Funding – Mayor Dawson

3. Redevelopment Proposal Support – Liberty and Tambo Apartments

Council Discussion led by Chairwoman Boggess

R Call for Resolution of support for the proposal from Ventural Industries, LLC., for the Redevelopment of Liberty and Tambo Apartments located at 1400 Liberty Park Blvd, in the City of Sedalia, Missouri – Mayor Dawson

B. PUBLIC WORKS – Chairman Bob Hiller; Vice Chairwoman Tina Boggess

1. Owner-agent Agreement – Amendment 1 – North and Central Wastewater Treatment Plants – HDR, Inc. \$105,637.00

Council Discussion led by Chairman Hiller

O Call for Ordinance Authorizing Amendment 1 to the Owner Agent Agreement for engineering Services for the City’s North and Central Wastewater Treatment Plants – Mayor Dawson

2. Change Order #1 – Storm Drainage Improvements – S&A Equipment and Builders – Project Area #8 – \$391,980.41

Council Discussion led by Chairman Hiller

O Call for Ordinance Approving and Accepting Change Order number one for Storm Drainage Improvements Project Area #8 – Mayor Dawson

3. Change Order #1 – Storm Drainage Improvements – S&A Equipment and Builders – Project Area #35 – \$67,240.31

Council Discussion led by Chairman Hiller

O Call for Ordinance Approving and Accepting Change Order number one for Storm Drainage Improvements Project Area #35 – Mayor Dawson

4. Change Order #2 – Storm Drainage Improvements – Orr Wyatt Streetscapes – Project Area #14 – \$4,857.25

Council Discussion led by Chairman Hiller

O Call for Ordinance Approving and Accepting Change Order number two for Storm Drainage Improvements Project Area #14 – Mayor Dawson

5. Change Order #1 – Storm Drainage Improvements – S&A Equipment and Builders – Project Area #28 – \$44,697.98

Council Discussion led by Chairman Hiller

O Call for Ordinance Approving and Accepting Change Order number one for Storm Drainage Improvements Project Area #28 – Mayor Dawson

6. Quote – 2025 Western Star 49X Dump Truck, Plow and Spreader – Premier Truck Group – \$297,541.00

Council Discussion led by Chairman Hiller

O Call for Ordinance Approving and Accepting a Quote for the purchase of a Dump Truck, Plow and Spreader – Mayor Dawson

7. Budget Amendment and Quote – Side Load Refuse Truck – Elliott Equipment Co. – \$299,000.00

Council Discussion led by Chairman Hiller

- R** Call for Resolution of the City Council of the City of Sedalia, Missouri, stating facts and reasons for the necessity to amend and increase the City's Annual Budget for the Fiscal Year 2025 – Mayor Dawson
 - O** Call for Ordinance Amending the Budget for the Fiscal Year 2024-2025 regarding Sanitation Side Load Refuse Truck purchase – Mayor Dawson
 - O** Call for Ordinance Approving and Accepting a Quote for the purchase of a Side Load Refuse Truck – Mayor Dawson
- 8.** Annexation & Utility Services Agreement – Connection to Water Distribution System -
– 1420 Timber Ridge Drive – Zakhariy Izoitza
Council Discussion led by Chairman Hiller
 - O** Call for Ordinance Authorizing an Annexation and Utility Services Agreement for connection of property located at 1420 Timber Ridge Drive to the City of Sedalia's Water distribution system – Mayor Dawson
- 9.** Annexation & Utility Services Agreement – Connection to Water Distribution System -
– 2685 James Lane – Herman S. and Debra K. Collier
Council Discussion led by Chairman Hiller
 - O** Call for Ordinance Authorizing an Annexation and Utility Services Agreement for connection of property located at 2685 James Lane to the City of Sedalia's Water distribution system – Mayor Dawson
- 10.** Budget amendment and Quote – Mobile Traffic Signals – J & A Traffic Products - \$56,781.26
Council Discussion led by Chairman Hiller
 - R** Call for Resolution of the City Council of the City of Sedalia, Missouri, stating facts and reasons for the necessity to amend and increase the City's Annual Budget for Fiscal Year 2025 – Mayor Dawson
 - O** Call for Ordinance Amending the Budget for the Fiscal Year 2024-2025 regarding Street Light Signals purchase – Mayor Dawson
 - O** Call for Ordinance Approving and Accepting a Quote for the purchase of two 4-Way Portable Signals – Mayor Dawson
- 11.** Agreement – Yard Waste Grinding – Hansen's Tree Service - \$39,275.00
Council Discussion led by Chairman Hiller
 - O** Call for Ordinance Authorizing an agreement for Yard Waste Grinding – Mayor Dawson
- 12.** Task Order 3A – Small Sanitary Sewer Project A – Engineering Surveys and Services
– \$21,300.00 – Design and Build & \$19,300.00 – Construction Management
Council discussion led by Chairman Hiller
 - O** Call for Ordinance Authorizing Task Order Number 3A for Small Sanitary Sewer Project A – Mayor Dawson
- 13.** Purchase of 2 Day Cab Trucks – H Crane LLC, dba Hannibal Crane Service – \$65,000.00
Council discussion led by Chairman Hiller
 - O** Call for Ordinance Approving and Accepting a Quote for the purchase of two Day Cab Trucks – Mayor Dawson

14. Budget Amendment and Blowers – Southeast Plant – FTC Equipment, LLC - \$370,920.00

Council discussion led by Chairman Hiller

R Call for Resolution of the City Council of the City of Sedalia, Missouri, stating facts and reasons for the necessity to amend and increase the City’s Annual Budget for Fiscal Year 2025 – Mayor Dawson

O Call for Ordinance Amending the Budget for the Fiscal Year 2024-2025 regarding WPC Blower purchases – Mayor Dawson

O Call for Ordinance Approving and Accepting a Quote for the purchase of two turbo Blowers for the Southeast Wastewater Treatment Plant – Mayor Dawson

15. Amend Right of Way Management Ordinance

Council discussion led by Chairman Hiller

O Call for Ordinance Amending Section 50-50 of the Code of Ordinances of the City of Sedalia, Missouri relating to the denial of an application for a Right-of Way Permit – Mayor Dawson

C. PUBLIC SAFETY - Chairman Jack Robinson; Vice Chairman Steve Bloess – No Report

D. COMMUNITY DEVELOPMENT – Chairwoman Rhiannon M. Foster; Vice Chairman Bob Cross – No Report

IV. OTHER BUSINESS

A. APPOINTMENTS - None

B. LIQUOR LICENSES

New:

*Kristy Long dba Wildlife Ridge Winery, 34751 Miller Rd., Smithton, Mo, Special Event (Sedalia Chamber of Commerce Picadilly – Foundry – 324 W 2nd – September 26, 2024, 8 AM – 1159 PM) - \$15.00

Renewals:

*Steven Swafford dba Grellner Sales & Service, 1510 West Henry, Wholesale Liquor & Wholesale Beer - \$350.00

*Doug Benitz dba Liberty Center Association, 111 West 5th, Liquor by the Drink - \$450.00

*Virginia K. Jones dba Prime Time #3, 1320 South Limit, Packaged Liquor & Sunday Sales - \$450.00

*Virginia K. Jones dba Prime Fav Trip, 216 West Broadway, Packaged Liquor & Sunday Sales - \$450.00

*Charles Wansing dba Chez When 121 East 3rd, Liquor by the Drink - \$450.00

*Cathy Geotz dba Break Time #3167, 101 Rebar Road, Packaged Liquor & Sunday Sales - \$450.00

*Chancey Sherman dba Chance’s R, 303 South Lamine, Liquor by the Drink, Sunday Sales and Sidewalk Consumption - \$800.00

*Eric Brown dba Buffalo Wild Wings, 4401 Wisconsin Ave, Liquor by the Drink and Sunday Sales - \$750.00

V. MISCELLANEOUS ITEMS FROM MAYOR, CITY COUNCIL AND CITY ADMINISTRATOR

VI. GOOD AND WELFARE- “During the 'Good and Welfare' section of our meeting agenda, we invite residents of Sedalia to step forward and directly address their City Council. Each participant is requested to clearly state their name and address and will have three minutes to present their statement. This session is specifically designed for residents to express their views or concerns; it is not intended for dialogue, debate, or question-and-answer interactions with the Council. All statements made during this time will be formally recorded in the public record. We urge participants to keep their remarks respectful and focused on matters relevant to our community. Your contributions are a vital part of our continuous efforts to enrich and improve Sedalia, and we thank you for adhering to these guidelines and helping us maintain the decorum of this important process.”

VII. Closed Door Meeting – Motion and Second to move into closed door meeting in the upstairs conference room pursuant to Subsections 1 (Legal Advice), 2 (Real Estate) and 12 (Negotiated Contracts) of Section 610.021 RSMo.

A. Roll Call Vote for Closed Door Meeting

B. Discussion of closed items

C. Vote on matters, if necessary (require a Roll Call Vote)

D. Motion and Second with Roll Call Vote to adjourn closed door meeting and return to open meeting

VIII. BUSINESS RELATED TO CLOSED DOOR MEETING

A. Motion and Second to reopen regular meeting

B. Roll Call

C. Approval of Closed-Door Meeting Items

IX. ADJOURN MEETING

A. Motion and second to adjourn meeting

Please join the meeting by clicking or touching this link from your smartphone, computer, tablet, or iPad:

<https://global.gotomeeting.com/join/578973061>

If this is the ***first time*** you have joined a GoToMeeting you will be asked to identify yourself. Please fill in this information. If you would like, and we suggest you do, go ahead and set your preferences to make it easier to join next time. If you are new to GoToMeeting? We suggest to get the app through the following link:

<https://global.gotomeeting.com/install/578973061> This will make joining these meetings quick and easy.

Once you have followed the link above and identified yourself you will be given options for how you want to join in with ***audio***.

For ***smartphones***: tap on one of the phone numbers and it will dial the phone and the meeting numbers.

For ***other devices***: use the feature of call me. The phone audio will be much better than through your computer. This should come up if you have your preferences set up to show it. If it does not, in the upper right-hand corner of the GoToMeeting screen you will see an icon that looks like a gear. Click on the gear and then look for "Phone" and if it is not highlighted click on it. One of the options should be to call me. Put the phone number you want to be called on (direct dial) into the box provided and then click the "Call Me" button. Once the system calls you, you will be asked to hit pound.

Please be mindful of others on the call by eliminating as much background noise as you can. Mute yourself until you are ready to speak. Do not put the call on hold, if you need to leave even for a short time, hang up as you can always dial back in after your other call. If you hear an echo or squeal, you may have your computer speakers on as well as the phone, mute your computer speakers to eliminate this.

If you want to join in ***listen only*** mode you can dial the following number and enter the access code.

(For supported devices, tap a one-touch number below to join instantly.)

United States (Toll Free): 1 866 899 4679

- One-touch: <tel:+18668994679,,578973061#>

United States: +1 (669) 224-3318

- One-touch: <tel:+16692243318,,578973061#>

Access Code: 578-973-061

The City Council reserves the right to discuss any other topics that are broached during the course of this meeting.

IF YOU HAVE SPECIAL NEEDS, WHICH REQUIRE ACCOMMODATION, PLEASE NOTIFY THE CITY CLERK'S OFFICE AT 827-3000. ACCOMMODATIONS WILL BE MADE FOR YOUR NEEDS

POSTED ON AUGUST 2, 2024 AT 3:30 P.M. AT THE SEDALIA MUNICIPAL BUILDING, BOONSLICK REGIONAL LIBRARY, SEDALIA PUBLIC LIBRARY AND ON THE CITY'S WEBSITE AT WWW.SEDALIA.COM



OFFICE OF THE CITY ADMINISTRATOR

To: Honorable Mayor Andrew L. Dawson & City Council Members
From: Kelvin Shaw, City Administrator
Re: Agenda items for City Council meeting on Monday, August 5, 2024, 6:30 p.m.

Finance/Administration Committee – There are three items for consideration through the Finance / Administration Committee.

1. We have encountered instances where we have arrested dealers of fentanyl only to have them take advantage of the loosened bail requirements to get right back out on the street. They then sell more drugs to pay for a lawyer to string out the time to even get them to a criminal trial in the Circuit Court system on the state charges. Many times, this takes a year or more, all the while they continue to prey on our community with their criminal activities. Further, sometimes right before they finally have to go to trial, they simply skip town to continue evading justice for their crimes. Prosecutor Smith, with his vast experience in fighting these battles, came up with a way to help us fill the gap in the system. The concept is to create a municipal violation that can run parallel to the state charges. Municipal violations are much more limited on the maximum jail time the judge can sentence them to, but still significant, while much more efficient in getting trials done quickly. Since the maximum sentence is much less than the state charges, we do not want to forgo the more serious state charges. Yet we do want to have something to fill the gap to stop these serious criminals from preying on our community much sooner than the time the state criminal system takes. The ordinance for your consideration will make it unlawful to have drug paraphernalia within the City of Sedalia. This will allow our police officers to arrest someone with fentanyl on state charges, as well as, arrest them for the paraphernalia that goes with it on municipal charges. The City Prosecutor can then file the charges on the municipal violation in municipal court, while at the same time the County Prosecutor can take the drugs themselves to the circuit court on the state charges. The suspect will still be allowed to seek bond on both the municipal and state charges pending trial. However, the municipal court docket moves much faster, and if convicted can be sentenced up to 90 days in jail. This keeps the dealer off the street for 90 of the days while the state criminal charges are awaiting trial. Part of the theory behind this approach, is that drug dealers are in the business of making money, and if they are in jail, they cannot be making money. Similarly, while they are in jail, the buyers of their drugs will seek out other dealers so they lose their addicted "customers." This then makes the cost of dealing drugs in Sedalia much higher. In turn, they will either find a legitimate way to make money or take their destructive behavior elsewhere. Prosecutor Smith has vetted this concept through a legal review of the statutes to make sure we were not violating double jeopardy laws, as well as, with the Police Chief and Municipal Judge. A discussion with Sheriff Anders and the County Prosecutor took place as well on the merits of this approach. Each of these stakeholders expressed support for this approach to making it tougher for these criminals to prey upon our community.

2. At your last meeting, the Chairwoman and Executive Director for the Embassy organization provided a presentation about their mission and then made a request for the use of some of the restricted funds the City is receiving from the opioid settlements. As discussed during that meeting, the use of these funds in this way, could serve a dual purpose from the City's perspective. First, it does support a successful program that is helping the community with substance abuse problems. Second, it helps with neighborhood revitalization. The Embassy laid out a list of needed repairs on the two houses with estimated costs totaling \$50,000. Council passed a motion to allocate up to \$50,000 of the opioid settlement funds for this purpose. Part of the discussion was on the process of reimbursing them based on actual invoices up to this amount. Also, Council expressed openness to reconsider the limit if costs were higher. Staff has prepared a budget amendment to formally appropriate these funds.
3. The owners of Liberty and Tambo Apartments on Liberty Park Blvd have put together a plan to rehabilitate these units. They are making an application for tax credits through the Missouri Housing Development Commission to help finance the project. A resolution by Council supporting the application is being requested for their application.

Public Works Committee – There are fifteen items for consideration through the Public Works Committee.

1. As we have been discussing, the City is under an Abatement Order on Consent (AOC) with Missouri Department of Natural Resources (MDNR) to bring the City's sewer treatment plants up to current standards. Particularly, the North Waste Water Treatment Plant was built in the 1940's with technology and standards from that time period. Due to the ever tightening of these standards and the changing loads in the sewage coming in, this technology will no longer meet the requirements. The voters were supportive in passing a measure in February to authorize us to borrow up to \$60M from the low interest State Revolving Fund (SRF) to replace the North Plant and upgrade the Central Plant. Due to the size and complexity of this project, staff recommends utilizing an Owners Agent to represent the City's best interest as we sort through the various options that will provide the best service to the citizens for at least the next generation. In accordance with the State Statutes, the SRF guidelines, and City policies, staff went through a process to review interested firms' qualifications to determine who would be in the best position to serve in this capacity. HDR, Inc. was determined to be the most qualified respondent to our request for qualifications. Staff worked with them to negotiate an agreement for the first phase of this path, and in April the agreement in the amount of \$77,902.00 was approved. We are nearing the end of phase one efforts of this contract, and in order to move forward with the next phase without delay, staff negotiated a scope of work for phase two. The services for this phase will get us through the process of design and procurement of construction at a cost of \$106,637.00. Staff recommends approval of adding this phase to the agreement.
2. In 2022, the City was successful in obtaining a grant through the American Rescue Plan Act (ARPA) for storm water improvements in eight different areas. These projects were part of the master plan developed a few years ago. As part of that planning process, the engineering was completed, which made our grant application more competitive over others and thereby successful. Once all eight projects were bid, the total of all bids awarded were \$535,461.15 below the total grant award. In working with the granting agency, additional options have been identified to utilize the rest of these available funds to further improve storm drainage

in the project areas. In order to receive approval from the Missouri Department of Natural Resources (MDNR), as the granting agency, these improvements have to be related to one of the project areas already approved and be in addition to the project scope rather than a complete redesign or another area entirely.

One such option that has been approved through the MDNR is in the area of Liberty Park. This addition will allow us to widen the paved area of Liberty Park Boulevard, add curbing, and more storm piping. Where the pavement is widened, we will be able to add angle parking to significantly increase the much-needed parking in for access to Liberty Park. Staff recommends a change order in the amount of \$391,980.41 to utilize available grant funds for this work.

3. As discussed on the last agenda item, we are working to utilize available grants to make more storm water improvements. Another option approved through MDNR is in the area of 13th Street and Beacon Avenue. This addition would replace a pipe that is failing and increase the size to handle larger rain events. Staff recommends allocating \$67,240.31 of these grant funds to this project area.
4. Continuing with change orders to make additional storm water improvements, staff has identified a need to modify the project in the area of Center Avenue and Broadway Boulevard. The cost for this change is \$4,857.25 and staff recommends approval of this change order.
5. In connection with the storm water improvement project in the area of 14th Street, Sneed Avenue, and Park Avenue, staff has worked with MDNR to get approval for the use of grant funding to replace sidewalks after the storm pipe is installed. This change will result in 11,870 square feet of sidewalk replacement at a cost of \$44,697.98. Staff recommends approval.
6. During the strategic planning and budgeting process, staff presented the need to replace a 1998 truck in the fleet that has exceeded its useful life and has a broken frame. Council prioritized this item as number two out of seven initiatives scored for transportation funding. With this level of prioritization, \$350,000 was included in the adopted budget. Staff located a dump body truck with plow and spreader under the state cooperative procurement contract for \$297,541.00, which will meet our needs and is \$52,459.00 under budget.
7. As discussed in December, the strategic plan included the need to replace garbage trucks that are at the end of their useful lives. At that time, we reported that we were experiencing equipment failures at a rate that was impeding our ability to keep trash picked up. We had so many failures at the same time that we had to have public works crews pick up trash with loaders and dump trucks, which is inefficient to say the least. Likewise, the repair costs to keep the old trucks operational, even part of the time, was excessive and consuming our fleet maintenance resources. Therefore, Council approved an accelerated proposal to move forward with some of the needed replacements. The current operations require four side loaders and two rear loading trucks. This number allows for one of each type to be in reserve to rotate in as needed when others are down for maintenance or repairs. When we entered into a lease purchase arrangement five years ago for the side loaders, the intent was that these trucks had an expected useful life in excess of seven years. This would allow us to start purchasing replacements one at a time at the end of the five-year amortization so that we could get them spread out on a rotational replacement schedule. However, these trucks have proven to be undersized for our needs, and therefore have not lasted as long as they were

anticipated to. Staff researched and identified heavier trucks that are more suitable to the usage that we put them through. Another part of the problem though, is that the Sanitation Fund does not have sufficient reserves to offset this level of purchase. Therefore, rather than going externally to borrow the funds or enter into a leasing arrangement, Council approved a loan from the General Fund to cover the purchase of two new trucks. The General Fund having sufficient reserves was able to cover this without unduly putting into jeopardy the financial stability of the City even when considering fluctuations in the economy or the ability to react to disasters. The rest of the plan was then to keep one of the three old trucks in daily service and keep the other two for backup. Our hope was that out of three we could keep one running. Then next fiscal year, we would purchase another new unit sized better for our use. Since then, this has become problematic to keep even one of these old trucks going. When reviewing this situation with the Public Works Council Committee last month, the Committee directed staff to bring forward a budget amendment to go forward now with the third replacement vehicles and get rid of the old trucks all together. Staff has located another such truck and negotiated a trade-in of all three of the old trucks on the one new replacement. The cost of the new truck is \$399,500 and they will allow \$100,500 trade-in value for the three old trucks. Staff recommends approval of the budget amendment and purchase of a new refuse truck utilizing a loan from the General Fund.

8. For the last few years, the City has required any properties outside the City limits that wanted to hook up to City Water and / or Sewer that they would have to agree to annex at such time the property becomes contiguous. Zakhariy Izoitza owns property at 1420 Timber Ridge Drive and wishes to connect to the City water utility. Therefore, staff has negotiated an annexation agreement and recommends approval.
9. Like the last agenda item, Herman and Debra Collier own property at 2685 James Lane and wish to connect to the City water utility. Therefore, staff has negotiated an annexation agreement and recommends approval.
10. During the special work session on the 9th of July, Council adopted a phased plan as recommended by staff and engineering consultants to get the Washington Street Bridge back in operation. The first phase of the plan was implemented right away to get the bridge open to northbound traffic only. The next part of the plan included purchasing portable traffic signal equipment to allow for two-way traffic on only one lane of the bridge. The lights would be green for northbound traffic and red for southbound, until the system sensors identified an automobile wanting to go south across the bridge. The lights would then change to red for northbound and green for southbound until the southbound traffic is cleared. This system of lights has been sourced and staff recommends purchase from J&A Traffic Products for \$56,781.26.
11. The City has, for several years now, collected tree limbs and other yard waste at the materials management site. Then, once or twice a year, a contractor brings in a large grinder to turn this debris into mulch. Much of this mulch is then used in the composting operation as a by-product of the sewer treatment operation. The sewer sludge that comes out of the sewer plants is mixed with the tree mulch and the biological process breaks down the materials and turns the mix into compost. This compost is then used by farmers, gardeners, and landscapers as a fertilizer. By doing this, the community receives several benefits. First, it provides an economical way to keep the yard debris picked up. Second, it recycles this yard waste into

useable products as either mulch or compost. Further, if not for being able to recycle the sewer sludge, the ratepayers, would incur more costs to properly dispose of this waste. Finally, the taxpayers and sewer ratepayers are able to recover some of the costs of this process from selling these byproducts. Staff has bid out the grinding and received three bids. The low bid was from Hansen's Tree Service at \$39,275, which is under the annual budget, leaving room if needed for later in the year. Hansen's Tree Service has performed these services well for the City before, so staff recommends approval.

12. The City has been working on a project to extend sewer to WireCo. The project was designed and let out for bid in May. However, no bids were received. Staff consulted with the engineers and potential contractors to determine why we did not generate interest in bidding this project. It was determined that a redesign is necessary to make the main extension easier to construct. Staff has worked with Engineering Surveys and Services on a scope of work to complete such a modification to the design. Staff recommends approval of a change order to this contract for \$40,600 for design and construction management services.
13. During the budgeting process, staff proposed and Council approved allocating \$65,000 for the purchase of another used day cab truck for use in pulling fifth wheel trailers. The public works divisions utilize different styles of trailers for various functions. A lowboy trailer is used to move large equipment, such as the paving machines. An end dump trailer is used to haul larger loads of aggregate or rock salt, such as when bringing it in from longer distances away. A step-down flatbed trailer is used to haul other equipment, such as back hoes or skid steers. These trailers are also used to haul things like the concrete barriers when setting up security for parades or blocking off streets. Having only one such truck capable of pulling these trailers, makes the operation less efficient and flexible. Therefore, adding another truck was proposed and budgeted. Staff located a good used truck for this purpose well under the budgeted amount. The dealer that has this truck also has another almost identical truck, and has offered a discount if we purchase both. With the discount, the two trucks can be purchased for the budgeted amount. Having three of these trucks would make the operations significantly more efficient, as well as, safe. When hauling equipment to job sites now, we are often pushing the limits of the current equipment capabilities. Using the right equipment that is designed to haul these loads is much safer. Therefore, staff recommends purchasing both of the used day cab trucks for a total cost of \$65,000.
14. With the current project to upgrade the Central Waste Water Treatment Plant, a major piece of the improvements is replacing and upgrading the blowers. An essential function to the process, is to pump air through the sewage to facilitate the biological breakdown of the solids in the waste water. While designing this upgrade, staff worked with the engineers to standardize the blower equipment used. By standardizing the blowers, our staff can operate and maintain them more efficiently. After careful consideration, it was decided to move away from the current positive displacement style of blowers to turbo style blowers. The turbo blowers have fewer moving parts, making them more reliable and easier to maintain. Also, the style of blowers selected includes permanent magnets in the place of bearings or bushings. This makes them more energy efficient by eliminating friction, while also removing parts that need maintenance and wear out. This information was presented to Council before approval of the purchase of this equipment was made for the Central Plant.

Now, the blowers at the South East Treatment Plant are failing. This plant too currently utilizes positive displacement style blowers. The current design has three units and is designed to rotate use so that we always have one or two units being held in reserve. In April, one of these units went down. As we were trying to repair this unit, we learned that the company that manufactured these blowers was sold, and the new owner had discontinued those models and further quit making parts for them. Still having two units running, staff did not get alarmed and planned on building into the next budget a replacement for the spare unit. However, since then another unit failed. We were able to rob parts off of the other down unit to get this unit back up. Then, the third unit also failed, leaving us with no parts to salvage to keep at least one blower going all the time. We were able to rent a portable unit to keep the plant going. However, that leaves us with less than efficient operations and no reliable back up. Staff worked with the supplier of the blowers selected for the Central Plant to provide a model that fits the needs of the South East Plant. They were able to provide specifications for a unit that is the same model, but less horsepower. Staff recommends purchasing two turbo style blowers for the South East Plant. Staff will continue to search for the best solution to provide the added backup protection for the blower systems. This may be a portable unit that can serve as backup to multiple plants. Staff will bring that recommendation back to Council at a later date. FTC Equipment is the sole provider for these units in this region and has quoted \$370,920.00 for the two units.

15. During the good and welfare portion of the last meeting, Carla Jackson came forward to express her concerns about the placement of fiber junction boxes in front of her residence. She reported that another fiber provider was in the process of placing the third junction box right in front of her house, and a fourth was recently removed but still has conduit sticking up. She was also informed there was a possibility of two more companies coming to town. She indicated she reached out to staff and her Councilmen, and while they were all courteous and working to help resolve this, they indicated that the City was limited in their powers to regulate utilities using the right of way. She requested that Council take whatever action they could as quickly as possible to limit the number of junction boxes that could be placed in front of one property. Since that meeting, our legal staff has performed a more extensive research of the state statutes and federal regulations that limit the City's abilities to affect this matter in relationship to our current right of way management codes. While the state and federal language does not clearly state we can dictate placement or style of these facilities, it does provide some room for us to manage the use of the right of way as long as our ordinances are reasonable and do not create an unfair advantage of one provider over another, among other limitations.

Pursuant to this research, our legal counsel has carefully crafted language to fit within the limitations that, when applied, will serve to limit the density of above ground or flush mounted junction boxes. Further, it will discourage the placement of boxes in the middle of properties by increasing landscaping requirements to conform with the surrounding aesthetics. Specifically, the ordinance will require junction boxes to be at least 75 feet apart, and within 10 feet of the property line. If it is not practical to be within 10 feet of the property line, then the provider may be required to put in reasonable landscaping to hide the junction boxes. Staff recommends approval of this amendment to the right of way management codes.

We are also happy to report that the provider that had put the third box right in front of Ms. Jackson's house did the right thing and moved this box.

Community Development Committee – There are no items for consideration through the Community Development Committee.

Public Safety Committee – There are no items for consideration through the Public Safety Committee.



CITY OF SEDALIA, MISSOURI
CITY COUNCIL MEETING
JULY 15, 2024

The City has an on-line broadcast of Council Meetings available both live and recorded by going to https://global.gotomeeting.com/join/578973061"

The Council of the City of Sedalia, Missouri duly met on July 15, 2024 at 6:30 p.m. at the Municipal Building in the Council Chambers with Mayor Pro-Tem Tina Boggess presiding. Mayor Pro-Tem Boggess called the meeting to order and asked for a moment of prayer led by Chaplain Byron Matson followed by the Pledge of Allegiance.

ROLL CALL:

Table with 4 columns: Name, Status, Name, Status. Rows include Jack Robinson, Thomas Oldham, Chris Marshall, Tina Boggess, Bob Hiller, Bob Cross, Rhiannon Foster, Steve Bloess.

SPECIAL AWARDS/SERVICE AWARDS /RETIREMENT AWARDS: None

MINUTES: The Council Meeting minutes of July 1, 2024, Special Council Meeting minutes of July 9, 2024 and the Council Work Session Meeting minutes of July 9, 2024, were approved on motion by Foster, seconded by Oldham. All in favor.

REPORTS OF SPECIAL BOARDS, COMMISSIONS & COMMITTEES:

The Citizen's Traffic Advisory Commission minutes dated May 20, 2024 were accepted on motion by Foster, seconded by Oldham. All in favor.

ROLL CALL OF STANDING COMMITTEES:

FINANCE & ADMINISTRATION – Chairwoman Tina Boggess; Vice Chairman Thomas Oldham

Presentation: Embassy

Board President Ann Graff, Executive Director Jason McClain and House Manager Brandon Stoner provided information regarding Embassy and their mission. The Embassy is a non-denominational, faith-based residential restoration organization for men. Their purpose is to assist those held captive in a life of brokenness, deception, manipulation; especially those with substance abuse disorders seeking a new productive and healthy life; realize they have a detrimental life controlling problem; and desire to change their life through a personal relationship with Jesus Christ. Their mission is "To minister to men, especially those with substance use disorders, by equipping, restoring and empowering, to commission them to be the men Christ formed them to be".

The Embassy provides a full continuum of care to support men in recovery including: Supportive housing, Peer support services/counseling, Community navigators/case management, and Connections to community-based services.

Brandon Stoner stated that in 2020 he was running the streets of Sedalia, a drug addict, dealing drugs, was arrested and spent time in the Pettis County Correctional Facility. When he was leaving the Missouri Department of Corrections, he looked for a program and housing that would help him succeed. When he joined Embassy, he just thought of it as a program but soon realized it wasn't a program but a lifestyle. While with Embassy, he built relationships within his community, with his employer and his family he never thought he could have. He has held his employment 2 ½ years with Gardner Denver, pursuing education through State Fair Community College in precision machining and industrial business management, and teaching others how to be better men. He teaches a weekly bible study at Lifepoint Church and was overwhelmed when the church gave him a key card to the building. He is now the restoration manager of the program to teach men the same lifestyle he decided to live.

Persons who participate in the program must fill out an application, be interviewed, pass a U.A. test allowing all personal property to be searched and enter a Bonding phase of 21 days to acclimate to the program. This includes surrendering all electronic devices, no unchaperoned outings, complete 60 hours of community service and complete curriculum. They must reside at the intake house the first 3 months while sharing a room, then to honor house with more freedom and their own room; upon successful completion of program, a graduation ceremony at 6 months with an alumni group who remain connected and accountable.

The Embassy has two locations: one at 322 West 7th and the other at 602 South Moniteau. They recently received a gift of a 10,000 sq. ft. facility in Pettis County and a vision of turning it into the intake home once legalities are completed. Their request is \$50,000.00 from the Opioid Settlement fund to complete Capital Improvements to their locations at 322 West 7th and 602 South Moniteau. City Administrator Kelvin Shaw stated that the Opioid Settlement funds have limited uses by State Statute and the agreement from the Judges passing the rulings. He stated that the amount the City has is \$103,248.41, of which a portion Council has committed to Bothwell Regional Health Center for a program which tracks opioids and what has been prescribed or any discrepancies. That will leave \$65,748.41 uncommitted and available. There are some funds in dispute of \$175,000.00 that have not been released, plus a \$24,000.00 installment from the payments which have been spread out over several years. That is a total of \$265,000.00 that should become available. Staff recommends approving the request and will bring a Budget amendment on August 5, 2024, City Council meeting for approval. Motion by Bloess, seconded by Foster to approve the request of \$50,000.00 for the Embassy Capital improvements. All in Favor.

Financial Update: Finance Director Jessica Pyle reported on Fiscal Year to Date Financials. Net Sales and Use tax is up Fiscal Year to Date over \$475,000.00 or 7.9% over prior Fiscal Year. A 4% increase was Budgeted and the City is to the positive over \$230,000.00 compared to Budget. Marijuana Sales tax has no comparison due to starting at the registers in August of previous year and payments received January 2024. Franchise tax remains lower than previous year primarily due to the Charter Settlement on Streaming Class Action and last year was over \$377,000.00 so the additional \$80,000.00 difference is related to lower gas tax which is down 45% Fiscal Year to Date. Transportation tax is higher due to gas tax which was up 9.8% Fiscal Year to Date and vehicle sales which is up 5.6% Fiscal Year to Date. Vehicle fees remain flat for Fiscal Year to Date. Property tax is slightly higher for Fiscal year but the bulk of the receipts are received in December and January.

- Ordinance waives open container laws and imposes other restrictions within the designated area for the "Oktoberfest Beer Garten and Food Fundraiser" event for Open Door hosted by The Local Tap. The event will be held October 12, 2024, from 11 a.m. to 6 p.m. downtown.

BILL NO. 2024-127, ORDINANCE NO. 12084 – AN ORDINANCE WAIVING OPEN CONTAINER LAWS AND IMPOSING OTHER CONDITIONS RELATING TO THE OPEN DOOR/THE LOCAL TAP "OKTOBERFEST BEER GARTEN AND FOOD FUNDRAISER" EVENT was read once by title.

2nd Reading – Motion by Oldham, 2nd by Marshall. All in favor.

Final Passage – Motion by Oldham, 2nd by Marshall. All in favor.

Roll Call Vote: Voting "Yes" were Robinson, Oldham, Marshall, Boggess, Hiller, Cross, Foster and Bloess. No one voted "No".

COMMUNITY DEVELOPMENT – Chairwoman Rhiannon M. Foster; Vice Chairman Bob Cross – No Report.

PUBLIC WORKS – Chairman Bob Hiller; Vice Chairwoman Tina Boggess

- The City has been successful in utilizing grant funds to maintain and add improvements to the airport. Airport Director Derrick Dodson has worked with engineers to identify specific projects from the overall master plan that would be favorable by the granting agency. The North 500 feet of the runway along with the parallel taxiway needs rehabilitation. The Grant is a 90/10 matching grant and the funds needed this fiscal year are \$18,800.00.

RESOLUTION NO. 2096 – A RESOLUTION AUTHORIZING THE SEDALIA REGIONAL AIRPORT TO SUBMIT A GRANT APPLICATION FOR REHABILITATION OF RUNWAY 18/36 was read once by title and approved on motion by Oldham, seconded by Foster. All in Favor.

RESOLUTION NO. 2097 – A RESOLUTION OF THE CITY COUNCIL OF THE CITY OF SEDALIA, MISSOURI, STATING FACTS AND REASONS FOR THE NECESSITY TO AMEND AND INCREASE THE CITY'S ANNUAL BUDGET FOR THE FISCAL YEAR 2025 was read once by title and approved on motion by Oldham, seconded by Foster. All in Favor.

BILL NO. 2024-128, ORDINANCE NO. 12085 – AN ORDINANCE AMENDING THE BUDGET FOR THE FISCAL YEAR 2024-2025 REGARDING AIRPORT LAND IMPROVEMENTS was read once by title.

2nd Reading – Motion by Oldham, 2nd by Foster. All in Favor.

Final Passage – Motion by Oldham, 2nd by Marshall. All in Favor.

Roll Call Vote: Voting "Yes" were Robinson, Oldham, Marshall, Boggess, Hiller, Cross, Foster and Bloess. No one voted "No".

- Ordinance authorizes an agreement with Roadway Asset Services to inventory the City's pavement and provide an index of the condition. Cost \$179,550.00

BILL NO. 2024-129, ORDINANCE NO. 12086 – AN ORDINANCE AUTHORIZING AN AGREEMENT FOR ROADWAY ASSET INVENTORY AND PAVEMENT INDEX SERVICES was read once by title.

2nd Reading – Motion by Foster, 2nd by Oldham. All in Favor.

Final Passage – Motion by Oldham, 2nd by Robinson. All in Favor.

Roll Call Vote: Voting "Yes" were Robinson, Oldham, Marshall, Boggess, Hiller, Cross, Foster and Bloess. No one voted "No".

- The Ordinance authorizes a scope of work from Wilson & Company for detailed design of the connection of the Katy Trail from the Katy Depot to Liberty Park. Cost \$194,715.15

BILL NO. 2024-130, ORDINANCE NO. 12087 – AN ORDINANCE AUTHORIZING A SCOPE OF WORK FOR DESIGN, PLANS AND SPECIFICATIONS FOR SIDEWALK CONSTRUCTION FOR THE KATY DEPOT – LIBERTY PARK CONNECT PROJECT was read once by title.

2nd Reading – Motion by Oldham, 2nd by Foster. All in favor.

Final Passage – Motion by Foster, 2nd by Oldham. All in favor.

Roll Call Vote: Voting “Yes” were Robinson, Oldham, Marshall, Boggess, Hiller, Cross, Foster and Bloess. No one voted “No”.

- The City has experienced recurring challenges in keeping consistent flow through mains to the Wastewater treatment plants due to tree roots and obstructions. Staff identified equipment during the Budgeting process that will not only address obstructions, but is also capable of installing bands to make repairs inside the pipe from the nearest manhole, alleviating the necessity of digging up pipe for repairs. Red Equipment, LLC. – Cost \$589,975.95

BILL NO. 2024-131, ORDINANCE NO. 12088 – AN ORDINANCE APPROVING AND ACCEPTING A QUOTE FOR THE PURCHASE OF A CAMERA AND CUTTER VEHICLE FOR THE UTILITIES DEPARTMENT was read once by title.

2nd Reading – Motion by Foster, 2nd by Oldham. All in favor.

Final Passage – Motion by Foster, 2nd by Oldham. All in favor.

Roll Call Vote: Voting “Yes” were Robinson, Oldham, Marshall, Boggess, Hiller, Cross, Foster and Bloess. No one voted “No”.

- The Resolution extends the license agreement for NUCOR another 90 days. NUCOR is working on a project to expand their portion of the rail spur to handle growth and make operations more efficient. Part of the expansion is on City owned property, requiring title work and agreement amendments to remain compliant with the Grant and Chapter 100 development agreement.

RESOLUTION NO. 2098 – A RESOLUTION OF THE CITY COUNCIL OF THE CITY OF SEDALIA, MISSOURI GRANTING NUCOR A LICENSE EXTENSION TO PERFORM GRADING IN ANTICIPATION OF A RAIL SPUR EXPANSION was read once by title and approved on motion by Oldham, seconded by Foster. All in Favor.

- Ordinance Authorizes an Initial Site Characterization Work Plan with AP Engineering and Consulting for property at East Broadway and South Hancock. This is in keeping with the agreement to continue to work on the remediation for the old petroleum storage tanks located during the due diligence period. Cost \$39,723.00

BILL NO. 2024-132, ORDINANCE NO. 12089 – AN ORDINANCE AUTHORIZING AN INITIAL SITE CHARACTERIZATION WORK PLAN FOR PROPERTY LOCATED AT EAST BROADWAY BOULEVARD AND SOUTH HANCOCK AVENUE was read once by title.

2nd Reading – Motion by Oldham, 2nd by Foster. All in favor.

Final Passage – Motion by Foster, 2nd by Oldham. All in favor.

Roll Call Vote: Voting “Yes” were Robinson, Oldham, Marshall, Boggess, Hiller, Cross, Foster and Bloess. No one voted “No”.

PUBLIC SAFETY - Chairman Jack Robinson; Vice Chairman Steve Bloess

Councilman Robinson asked Fire Chief Matt Irwin to talk about the air renewal system in the new squad truck. Fire Chief Irwin stated that one of the features is a cascade type system with four 6,000-pound air bottles in the frame of the truck. This allows the Fire Department to fill air apparatus equipment on scene versus having to run them back to fill at the station. The vehicle also has the capacity to house equipment to be a rescue vehicle. Its main purpose is to run between 1700-1800 medical calls instead of the Fire Engines.

APPOINTMENTS: None

LIQUOR LICENSES: The following renewal Liquor Licenses were read and approved on motion by Oldham, seconded by Foster. All in Favor.

- *Honor Villalobos dba Kehdes BBQ, 1915 South Limit, Sunday Sales
- *Joshua Moore dba Casey's General Store #1601, 3500 West 16th, Packaged Liquor & Sunday Sales
- *Anthony Douglas dba Casey's General Store #1063, 1909 West Main, Packaged Liquor & Sunday Sales
- *Victoria Dotson dba Casey's General Store #2347, 1601 East Broadway, Packaged Liquor & Sunday Sales
- *Kristina Moore dba Casey's General Store #3257, 3050 South Limit, Packaged Liquor & Sunday Sales
- *Teri Bates dba Casey's General Store #1052, 716 West 16th, Packaged Liquor & Sunday Sales
- *Nicole Walker dba Discount Smokes & Liquor, 2205 South Limit, Packaged Liquor & Sunday Sales

MISCELLANEOUS ITEMS FROM MAYOR/COUNCIL/ADMINISTRATOR:

Mayor Pro-Tem Boggess thanked City Engineer Chris Davies and his team for their efforts in getting the Washington Street Bridge open.

Councilwoman Foster announced that when the Governor signed the Budget, funding was included to have the intersection at 32nd and Limit redone.

City Administrator Kelvin Shaw congratulated the Fire Department for leading the effort to bring our ISO rating down to a 2. Only 7% of Fire Departments are able to achieve this level.

GOOD & WELFARE:

David Goodson, 1640 Hedge Apple Drive, stated that the City went to court and it didn't go well. The end result will be an evacuation plan which Mr. Goodson is certain Sherriff Anders already has and funds were spent that could have gone to other City projects. He feels we shouldn't handle tax payer monies any different than our own.

Carla Jackson, 1815 West 5th, voiced concern with the addition of the 5G installation. She stated she has 3 boxes in her yard with the most recent one being placed in the middle of her yard. There was a fourth box but it has disappeared, however, there is tubing next to the utility pole. Her fear is that before anything can be done, another company will come in to place another box. She is not opposed to 5G, but she would like there to be a limit on the number of boxes/towers in a person's yard.

Debbie Covington, 2601 East 12th, asked at the last Council meeting if Council was aware that Leachate is being dumped into the Wasterwater facility by the Landfill. Between then and now, with the help of the Department of Natural Resources and others it has been confirmed that there is 400,000-500,000 gallons being dumped into the water every month. She feels it is an issue that the City and County need to address.

Michelle Swords, 300 South Ohio, commented on the Katy Depot-Liberty Park connect project. There was a 6-8-month period she tried to reach out regarding the project but the Council contact information was not on the website. Now some of the Council members have their address listed as the City's as well as a City phone number which she feels is not right. Ms. Swords stated that she was disappointed when the project came out on the agenda because those affected were not contacted and given the opportunity for input.

The meeting adjourned at 7:35 p.m. on motion by Oldham, seconded by Foster to a closed-door meeting in the upstairs conference room pursuant to subsections 1 (Legal Advice), 2 (Real Estate) and

12 (Negotiated Contracts) of Section 610.021 RSMo. Roll Call Vote: Voting "Yes" were Robinson, Oldham, Marshall, Boggess, Hiller, Cross, Foster and Bloess. No one voted "No".

The regular meeting reopened at 8:35 p.m. on motion by Oldham, seconded by Robinson.

ROLL CALL:

| | | | |
|----------------|---------|-----------------|---------|
| Jack Robinson | Present | Bob Hiller | Present |
| Thomas Oldham | Present | Bob Cross | Present |
| Chris Marshall | Present | Rhiannon Foster | Present |
| Tina Boggess | Present | Steve Bloess | Present |

BUSINESS RELATED TO CLOSED DOOR MEETING:

BILL NO. 2024-133, ORDINANCE NO. 12090 – AN ORDINANCE APPROVING A QUIT CLAIM DEED FOR THE SALE OF PROPERTY COMMONLY KNOWN AS 534 EAST 4TH STREET FROM THE CITY OF SEDALIA, MISSOURI TO THE JIMMY LAURIE FAIRFAX SR TRUST was read once by title.

2nd Reading – Motion by Oldham, 2nd by Marshall. All in Favor.

Final Passage – Motion by Oldham, 2nd by Marshall. All in Favor.

Roll Call Vote: Voting "Yes" were Robinson, Oldham, Marshall, Boggess, Hiller, Cross, Foster and Bloess. No one voted "No".

The regular meeting adjourned at 8:39 p.m. on motion by Oldham, seconded by Cross. All in favor.

THE CITY OF SEDALIA, MISSOURI

Tina Boggess, Mayor Pro-Tem

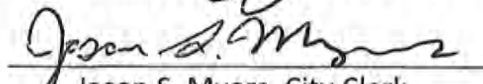
Jason S. Myers, City Clerk

BILL NO. _____

ORDINANCE NO. _____

AN ORDINANCE OF THE CITY OF SEDALIA MISSOURI TO PROHIBIT UNLAWFUL USE OF DRUG PARAPHERNALIA WITH FENTANYL

WHEREAS, the City of Sedalia, like most communities, has tragically suffered loss of life due to the epidemic of illegal fentanyl abuse; and

WHEREAS, the Mayor and Council believes that increased criminal penalties for trafficking fentanyl will decrease the availability of fentanyl in Sedalia; and

WHEREAS, the Mayor and Council believes that a decrease in the availability of fentanyl will save lives in Sedalia and surrounding communities; and

WHEREAS, the current process for prosecution of fentanyl dealers by the State of Missouri often has the defendant drug dealers out of jail for months awaiting trial, during which time they continue to traffic fentanyl and endanger lives; and

WHEREAS, the City Code already criminalizes the use of scales to test and analyze controlled substances and criminalizes the use of containers or bags to store or conceal controlled substances as unlawful use of drug paraphernalia; and

WHEREAS, a municipal offense has a statutory maximum jail sentence of ninety (90) days in jail; and

WHEREAS, the Mayor and Council desire that any defendant charged by the State of Missouri with felony drug trafficking additionally be given a municipal charge of unlawful use of drug paraphernalia when items have been used in such trafficking; and

WHEREAS, the Mayor and Council, in their desire to dissuade fentanyl trafficking, desire that any defendant who pleads or is found guilty of using paraphernalia to traffic fentanyl or a fentanyl derivative be sentenced to the maximum jail term of ninety (90) days; and

WHEREAS, the Sedalia Police Department possess a TruNarc laser drug tester that the Mayor and Council desire to be used to prove the items of paraphernalia were used to traffic fentanyl in court to prosecute the defendant drug dealers.

NOW, THEREFORE, BE IT ORDAINED BY THE CITY COUNCIL OF THE CITY OF SEDALIA, MISSOURI AS FOLLOWS:

SECTION 1: §36-236 Unlawful Use of Drug Paraphernalia

(b) In the event that a defendant is charged by the State of Missouri with either first- or second-degree trafficking (§579.065, RSMo. or §579.068, RSMo.) of fentanyl or a fentanyl derivative, the City of Sedalia shall be authorized to bring a municipal charge of unlawful paraphernalia with

fentanyl. In such circumstances, the ordinance shall carry a mandatory ninety (90) day jail term, said sentence to be commenced immediately upon guilty plea or conviction. At trial, the results of a NarTec laser field test shall be admissible to prove the presence of fentanyl on the subject paraphernalia. Any identifiable mass of fentanyl, no matter how small, will be sufficient for a conviction under this section. A valid prescription in the name of the defendant for fentanyl will be admissible at trial.

(c) The purpose of this section is to limit the danger fentanyl dealers present to the public while awaiting trial on state felony charges, a process which can take many months.

SECTION 2: The provisions of any ordinance or code section in conflict with any provision of this ordinance are hereby repealed to the extent of such conflict.

SECTION 3: This ordinance shall be in full force and effect following final passage and approval.

SECTION 4: The provisions of this ordinance are severable and if any provision hereof is declared invalid, unconstitutional, or unenforceable, such determination shall not affect the validity of the remainder of this ordinance.

Read two times by title, copies of the proposed ordinance having been made available for public inspection prior to the time the bill is under consideration by the Council and passed by the Council of the City of Sedalia, Missouri this 5th day of August 2024.

Presiding Officer of the Council

Approved by the Mayor of said City this 5th day of August 2024.

Andrew L. Dawson, Mayor

ATTEST:

Jason S. Myers
City Clerk

**CITY COUNCIL
OF THE CITY OF SEDALIA, MISSOURI**

RESOLUTION NO. _____

**A RESOLUTION OF THE CITY COUNCIL OF THE CITY OF SEDALIA, MISSOURI,
STATING FACTS AND REASONS FOR THE NECESSITY TO AMEND AND INCREASE
THE CITY'S ANNUAL BUDGET FOR FISCAL YEAR 2025.**

WHEREAS, Section 67.010 of the Revised Statutes of Missouri requires each political subdivision of the State of Missouri ("State") to prepare an annual budget and establishes the requirements for that budget; and

WHEREAS, the City of Sedalia, Missouri ("City"), is a city of the third classification created pursuant to Chapter 77, RSMo, and is a political subdivision of the State of Missouri; and

WHEREAS, the City Council of the City adopted and approved the City's annual budget for Fiscal Year 2025 in accordance with the requirements of Section 67.010, RSMo, by Ordinance No. 11990 on March 18, 2024, and

WHEREAS, Sections 67.030 and 67.040 authorize and provide a procedure for the City Council to amend the City's annual budget to increase expenditures in any fund; and

WHEREAS, expenses for City's operations for Fiscal Year 2025 have been higher than budgeted, but do not exceed revenues plus the City's unencumbered balance brought forward from previous years; and

WHEREAS, the City Council of the City desire to state the facts and reasons necessitating an amendment to increase certain expenditures in the Fiscal Year 2025 annual budget.

NOW THEREFORE, BE IT RESOLVED BY THE CITY COUNCIL OF THE CITY OF SEDALIA, MISSOURI, AS FOLLOWS:

Section 1. Expenditures from the City's Opioid Settlement Fund must be increased by a total of \$50,000 above the amount authorized in the adopted annual budget for Fiscal Year 2025. An amendment to increase said budget is necessary for the following facts and reasons:

A. Fulfill Embassy funding request.

Section 2. This Resolution shall take effect immediately upon its execution by the Mayor or otherwise as provided by law.

PASSED by the City Council of the City of Sedalia, Missouri, on August 5, 2024

Presiding Officer of the Council

ATTEST: _____
Jason S. Myers, City Clerk

BILL NO. _____

ORDINANCE NO. _____

**AN ORDINANCE AMENDING THE BUDGET FOR THE FISCAL YEAR 2024-2025
REGARDING EMBASSY FUNDING.**

**NOW THEREFORE, BE IT ORDAINED BY THE COUNCIL OF THE CITY OF
SEDALIA, MISSOURI** as follows:

Section 1. The 2024-2025 fiscal year budget beginning April 1, 2024 and ending March 31, 2025 is hereby amended to modify certain budgeted line items as they appear on the attached schedule and made a part hereof as Exhibit A as if fully set out herein.

Section 2. This ordinance shall be in full force and effect from and after its passage and approval.

Read two times by title, copies of the proposed ordinance having been made available for public inspection prior to the time the bill is under consideration by the Council and passed by the Council of the City of Sedalia, Missouri this 5th day of August 2024.

Presiding Officer of the Council

Approved by the Mayor of said City this 5th day of August 2024.

Andrew L. Dawson, Mayor

ATTEST:

Jason S. Myers
City Clerk

Exhibit A
 City of Sedalia
 FY25 Budget Amendment 8/5/2024 Admin Embassy Funding

| Account / Description | Current Budget | Change | Amended Budget | Comments |
|---|-------------------|--------------------|-------------------|--|
| Expenditures / Uses of Funds 26-26-255-00 Opioid Settlement Prevention | - | 50,000.00 | 50,000.00 | Embassy Funding Request |
| Total Expenditure Change | | <u>50,000.00</u> | | |
| | | <u>(50,000.00)</u> | | Net Increase (Decrease) in Projected Fund Balance |

RESOLUTION NO. _____

A RESOLUTION OF SUPPORT FOR THE PROPOSAL FROM VENTURAL INDUSTRIES, LLC., FOR THE REDEVELOPMENT OF LIBERTY AND TAMBO APARTMENTS LOCATED AT 1400 LIBERTY PARK BLVD, IN THE CITY OF SEDALIA MISSOURI.

WHEREAS, Ventura Industries, LLC, is proposing to rehabilitate Liberty and Tambo Apartments (to be named Liberty Apartments); and

WHEREAS, Ventura Industries, LLC., wishes to apply for financing and tax credits available through the Missouri Housing Development Commission as stated in the 2024 MHDC Multi-Family Rental Production Program Notice of Funding Availability; and

WHEREAS, the City Council recognizes the need for safe, affordable, quality housing for low-income households, and supports the proposal from Ventura Industries, LLC.

NOW, THEREFORE, BE IT RESOLVED BY THE CITY COUNCIL OF THE CITY OF SEDALIA, MISSOURI, AS FOLLOWS:

Section 1. The City hereby expresses its support for the proposal from Ventura Industries, LLC for the 2024 Multi-Family Rental Production Program Notice of Funding Availability, for the rehabilitation of the development located at 1400 Liberty Park Blvd, in the City of Sedalia, Missouri.

Section 2. This Resolution shall be in full force and effect after its passage and approval.

PASSED by the Council of the City of Sedalia, Missouri, this 5^h day of August, 2024.

Presiding Officer of the Council

ATTEST:

Jason S. Myers
City Clerk

BILL NO. _____

ORDINANCE NO. _____

AN ORDINANCE AUTHORIZING AMENDMENT 1 TO THE OWNER AGENT AGREEMENT FOR ENGINEERING SERVICES FOR THE CITY'S NORTH AND CENTRAL WASTEWATER TREATMENT PLANTS.

WHEREAS, the City of Sedalia, Missouri, has received Amendment No. 1 to the Owner Agent Agreement from HDR Engineering, Inc. for engineering services for the City's North and Central Wastewater Treatment Plants; and

WHEREAS, under the terms of the Agreement, the City of Sedalia shall pay the sum and amount of One Hundred Five Thousand Six Hundred Thirty-seven Dollars (\$105,637.00) to HDR Engineering, Inc. for said engineering services as more fully described in the agreement attached to this Ordinance and incorporated by reference herein.

NOW THEREFORE, BE IT ORDAINED BY THE COUNCIL OF THE CITY OF SEDALIA, MISSOURI, as follows:

Section 1. The Council of the City of Sedalia, Missouri, hereby approves and accepts Amendment 1 to the owner agent agreement by and between the City of Sedalia, Missouri and HDR Engineering, Inc. attached hereto and incorporated by reference as though the proposed agreement were set forth herein in substantially the same form and content as proposed.

Section 2. The Mayor or City Administrator are authorized and directed to execute and the City Clerk is hereby authorized and directed to attest and fix the seal of the City of Sedalia, Missouri, on the document as it has been proposed.

Section 3. The City Clerk is hereby directed to file in his office a duplicate or copy of the document after as it has been executed by the parties or their duly authorized representatives.

Section 4. This ordinance shall take effect and be in full force and effect from and after its passage and approval.

Read two times by title, copies of the proposed ordinance having been made available for public inspection prior the time the bill is under consideration by the Council and passed by the Council of the City of Sedalia, Missouri this 5^h day of August, 2024.

Presiding Officer of the Council

Approved by the Mayor of said City, this 5^h day of August, 2024.

Andrew L. Dawson, Mayor

ATTEST:

Jason S. Myers
City Clerk

MEMO

TO: Mayor and City Council

THRU: Kelvin L. Shaw, City Administrator
Matthew Wirt, Assistant City Administrator

FROM: Christopher R. Davies, P.E., City Engineer

SUBJECT: PHASE 2 – OWNERS AGREEMENT BETWEEN THE CITY OF SEDALIA AND HDR, INC.

DATE: July 31, 2024

Background:

The City is in the process of replacing their North WWTP and build a new North WWTP at a new location (site has been secured), The City has already secured a \$60M bond authority for this purpose through the election process in early February 2024. It is the City's intent to apply for a State Revolving Fund (SRF) loan for the proposed improvements. In applying for SRF Funding, this will afford the City a very low interest rate and may open up opportunities for Grants.

The City has also selected a Design/Build Engineering firm (Burns and McDonnell) and an Owners Agent (HDR, Inc.) through the RFQ process as required by state law and meeting the requirements of the SRF process.

Discussion:

This is the first time the City of Sedalia will complete a design/build project of this scale. The main purposes of a Design/Build process are: 1) to save time in the overall project, and 2) reduce cost of the project. However, the majority of cities do not have staff on board that have the overall expertise to cover all of the disciplines required for a project of this size and scope, which is the case for the City of Sedalia. That is the purpose and why the City has selected to move forward with engaging an Owners Agent (HDR, Inc.)

The first phase (Phase 1) of the work, which is nearing completion, has already been approved by City Council and included: 1) review data and gaps in data from the Central and North WWTP's, 2) to meet with the City, our Design/Build Team (Burns and McDonnell), HDR, Inc., and 3) determine/define the project and best/most efficient path forward to accomplish the goal of replacing the North WWTP and upgrading the Central WWTP to be in compliance within budget.

The second phase of the work (Phase 2), which we are seeking approval for includes the following, additional detail is in the attached contract from HDR:

1. Project Management and Administration
2. Facility Plan (be the City expert in Design/Build process)
3. Industrial Pretreatment Program Evaluation
4. Design-Builder Procumbent support

HDR proposes to amend the original contact that was approved by City Council (approved amount was \$78,000.00 on 4/1/2024) in the amount of \$106,637.00 bringing the Total Contract amount (original contract plus amendment 1) to \$183,637.00. It should be noted the City has already paid HDR Inc., \$45,877.72 per the original agreement thru worked performed thru July 2024.

Recommendation:

City staff recommends the City Council approve Amendment 1, to Agreement for Engineering Services date April 1, 2024 between HDR, Inc. and the City of Sedalia, in the amount of \$105,637.00 and authorizing the Mayor or City Administrator to sign said agreement.

AMENDMENT 1 TO AGREEMENT
FOR
ENGINEERING SERVICES

WHEREAS:

HDR ENGINEERING, INC. ("HDR") entered into an Agreement on April 1, 2024 to perform Owner's Representative Services ("Project");

City of Sedalia desires to amend this Agreement in order for HDR to perform services beyond those previously contemplated;

HDR is willing to amend the agreement and perform the additional engineering services.

NOW, THEREFORE, HDR and City of Sedalia do hereby agree:

The Agreement and the terms and conditions therein shall remain unchanged other than those sections and exhibits listed below;

Section IV Compensation shall be amended as follows:

Compensation for ENGINEER'S services under this Agreement shall be based on Hourly Rates (Direct Labor Costs Times a Factor of 3.2 for the services of Engineer's personnel engaged on the project), plus Reimbursable Expenses, for a Not-to-Exceed amount of One Hundred Eighty Three Thousand Six Hundred Thirty Seven Dollars (\$183,637) within the limits of the Hourly Rate Schedule attached as Exhibit C. The Hourly Rate Schedule will be adjusted annually with no change to the not-to-exceed amount provided the Scope of Services does not change.

| | |
|--------------------------------------|---------------|
| Original Not-To-Exceed Amount: | \$ 78,000.00 |
| Amendment 1 Not-to-Exceed Amount: | \$ 105,637.00 |
| Total Contract Not-to-Exceed Amount: | \$ 183,637.00 |

Exhibit A shall be amended to include Exhibit A-1.

IN WITNESS WHEREOF, the parties hereto have executed this Amendment as of the day and year written below:

HDR ENGINEERING, INC. ("HDR") _____ ("_____")

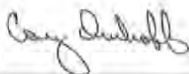
By: 

By: _____

Title: Senior Vice President

Title: _____

Date: Jul 30, 2024

Date: _____

EXHIBIT A-1
ENGINEER SCOPE OF SERVICES
CITY OF SEDALIA, MISSOURI
OWNER'S REPRESENTATIVE SERVICES
for the

WASTEWATER TREATMENT PLANT IMPROVEMENT PROJECT

OVERVIEW

The Owner's Representative Services for the City of Sedalia (City) Wastewater Treatment Plant is to advise and assist the City in the Facility Plan phase of this project, which is currently planned as Phase 1-A of the Progressive Design Build delivery method. HDR Engineering (Consultant) will provide project management, integrated project delivery, and wastewater treatment engineering experience and expertise during the Facility Plan phase of the project.

The time of service shall be 270 days from the Owner's execution of this agreement and notice to proceed.

A. PROJECT MANAGEMENT ADMINISTRATION

A.1 Project Management and Administration

Conduct project management and administration activities for the anticipated schedule of the project including project initiation, project billing and written status updates (if requested), team management, schedule and budget management, and coordination with City.

Deliverables:

Invoices
Project status updates

B. Facility Plan

B.1 Progress Meetings

Participate in Project meetings held by Design-Builder (Six meetings, up to three in Sedalia). Review meeting minutes prepared by Design-Builder and provide comments.

B.2 Review Design Builder's workplan

Review and provided comments on Design Builder's work plan.

B.3 Coordinate MDNR/SRF Project Meetings and Correspondence

Participate in project meetings held by Design-Builder and correspondence with MDNR (Up to two meetings)

B.4 Flow and Load Projections

Review and provide comments on Design Builder's Flow and Loading TM.

B.6 Antidegradation Review and Regulatory Guidance

- a. Participate in up to two meetings with MDNR (Assumes both meetings are virtual)
- b. Review and provide comments on Design-Builder's antidegradation analysis and modeling approach.

- c. Review and provide comments on Design-Builder's draft antidegradation report.
- d. Review and provide comments on draft operating permit.

B.7 Field Verification Site Visit

Participate in field verification site visit to include a site walk of the Central WWTP, North WWTP, and proposed North WWTP. Review minutes prepared by Design Builder and provide comments.

Deliverables:

Comments on Design Builder deliverables:

- Meeting Minutes (6)
- Work Plan
- Flow and Load TM
- Site visit minutes
- Long-term sampling plan

B.8-9 Design-Builder Alternative Evaluation and Recommendation Review

- Consultant will participate in preliminary biological screening meeting and biological process workshop with Owner and Design-Builder.
- Consultant will participate in Design-Builder Alternatives Evaluation workshops.
- Consultant will review Design-Builder Alternatives Evaluation and Recommendations and provide comments.
- Consultant will review cost estimates developed by Design Builder and provide comments.
- Consultant will participate in value engineering evaluation and develop list of proposed modifications and associated cost savings.

B.10 Facility Plan Report Review

- Consultant will review the Design-Builder's Facility Plan Report, participate in the Facility Plan review meeting, and provide comments.

Deliverables:

Comments on Design-Builder deliverables:

- Alternative Evaluation
- Cost Estimate (One estimate anticipated)
- Value Engineering Technical Memo

C. Industrial Pretreatment Program Evaluation

C.1 Participate in meeting with Design-Builder, City and Contract Operator to review current practices related to pretreatment. Observe sampling and inspection by Owner or Contract Operator for two industrial users.

C.2 Review draft report prepared by Design-Builder and provide comments.

Deliverables:

Comments on Design-Builder deliverables:
Pretreatment recommendations report

D. DESIGN-BUILDER PROCUREMENT SUPPORT

E.1 Consultant will conduct workshop with City to evaluate procurement strategies for completing the project.

Deliverables:

Meeting minutes

WWTP Improvements - Owners Advisor - Amendment 1
 Facility Plan
 Scope and Fee Estimate - July 17, 2024

| Task | Staff Name | Young, P Project Principal | C'Donk, L Senior Project Manager | Caran, D Senior Water Quality | Adams-Walker, J Technical Specialist II | Mankie, R Project Engineer/Process Control Engineer | Kokk, B Kartificial Project Engineer | DeCruz, C Support Staff | Biggs, J Support Staff | Boys, T Senior Electrical/Electronics | Wissman, D Technical Specialist/Instrumentation | Duffy, C Electrical/Electronics Instrumentation | Christiansen, J Senior Environmental/Environmental Health | Hirshvogel, L Senior Environmental/Environmental Health | Brennweit, P Technical Specialist/Instrumentation | Bennison, M Senior Project Engineer/Control | Total RFP Hours | RFP Estimate | Total |
|---|------------|-------------------------------|-------------------------------------|----------------------------------|--|--|---|----------------------------|---------------------------|--|--|--|--|--|--|--|-----------------|--------------|----------|
| | | | | | | | | | | | | | | | | | | | |
| 2. PROCESS IMPROVEMENTS ADMINISTRATION | | | | | | | | | | | | | | | | | | | |
| 1) Project Engineering | | 4 | 5 | 0 | 0 | 0 | 0 | 0 | 0 | 0 | 0 | 0 | 0 | 0 | 0 | 0 | 31 | | |
| 2) Process Control | | 51,600 | \$2,295 | \$0 | \$0 | \$0 | \$318 | \$995 | \$0 | \$0 | \$0 | \$0 | \$0 | \$0 | \$0 | \$0 | 31 | \$0 | \$6,600 |
| 3. FACILITY PLAN | | | | | | | | | | | | | | | | | | | |
| 1) Progress Meetings | | | 17 | 9 | | 9 | | | | | | | | | | | 35 | \$250 | \$8,750 |
| 2) Review CB Writings | | | 1 | 7 | | 7 | | | | | | | | | | | 8 | \$250 | \$2,000 |
| 3) Coordinate Meetings and Correspondence with MDNR | | | 6 | 8 | | 8 | | | | | | | | | | | 14 | \$250 | \$3,500 |
| 4) Review Plans and Loading TDI | | | 4 | 17 | | 17 | | | | | | | | | | | 21 | \$250 | \$5,250 |
| 5) Finalization Review | | | 2 | 4 | | 4 | | | | | | | | | | | 6 | \$250 | \$1,500 |
| 6) Review and Approval | | | 3 | 4 | | 4 | | | | | | | | | | | 7 | \$250 | \$1,750 |
| 7) Alternatives screening | | | 4 | 14 | | 14 | | | | | | | | | | | 18 | \$250 | \$4,500 |
| 8) Alternatives evaluation workshop | | | 14 | 36 | | 36 | | | | | | | | | | | 50 | \$250 | \$12,500 |
| 9) Cost estimate review | | | 2 | 24 | | 24 | | | | | | | | | | | 26 | \$250 | \$6,500 |
| 10) Value Engineering | | | 8 | 16 | | 16 | | | | | | | | | | | 24 | \$250 | \$6,000 |
| 11) Review Draft FP | | | 4 | 4 | | 4 | | | | | | | | | | | 8 | \$250 | \$2,000 |
| 12) Presentation | | | 15 | 8 | | 8 | | | | | | | | | | | 23 | \$250 | \$5,750 |
| 13) Recruitment Workshop | | | 6 | 8 | | 8 | | | | | | | | | | | 14 | \$250 | \$3,500 |
| 14) Local News | | | 8 | 16 | | 16 | | | | | | | | | | | 24 | \$250 | \$6,000 |
| 15) Local News | | | 15 | 16 | | 16 | | | | | | | | | | | 31 | \$250 | \$7,750 |
| 16) Local News | | | 15 | 16 | | 16 | | | | | | | | | | | 31 | \$250 | \$7,750 |
| 17) Local News | | | 15 | 16 | | 16 | | | | | | | | | | | 31 | \$250 | \$7,750 |
| 18) Local News | | | 15 | 16 | | 16 | | | | | | | | | | | 31 | \$250 | \$7,750 |
| 19) Local News | | | 15 | 16 | | 16 | | | | | | | | | | | 31 | \$250 | \$7,750 |
| 20) Local News | | | 15 | 16 | | 16 | | | | | | | | | | | 31 | \$250 | \$7,750 |
| 21) Local News | | | 15 | 16 | | 16 | | | | | | | | | | | 31 | \$250 | \$7,750 |
| 22) Local News | | | 15 | 16 | | 16 | | | | | | | | | | | 31 | \$250 | \$7,750 |
| 23) Local News | | | 15 | 16 | | 16 | | | | | | | | | | | 31 | \$250 | \$7,750 |
| 24) Local News | | | 15 | 16 | | 16 | | | | | | | | | | | 31 | \$250 | \$7,750 |
| 25) Local News | | | 15 | 16 | | 16 | | | | | | | | | | | 31 | \$250 | \$7,750 |
| 26) Local News | | | 15 | 16 | | 16 | | | | | | | | | | | 31 | \$250 | \$7,750 |
| 27) Local News | | | 15 | 16 | | 16 | | | | | | | | | | | 31 | \$250 | \$7,750 |
| 28) Local News | | | 15 | 16 | | 16 | | | | | | | | | | | 31 | \$250 | \$7,750 |
| 29) Local News | | | 15 | 16 | | 16 | | | | | | | | | | | 31 | \$250 | \$7,750 |
| 30) Local News | | | 15 | 16 | | 16 | | | | | | | | | | | 31 | \$250 | \$7,750 |
| 31) Local News | | | 15 | 16 | | 16 | | | | | | | | | | | 31 | \$250 | \$7,750 |
| 32) Local News | | | 15 | 16 | | 16 | | | | | | | | | | | 31 | \$250 | \$7,750 |
| 33) Local News | | | 15 | 16 | | 16 | | | | | | | | | | | 31 | \$250 | \$7,750 |
| 34) Local News | | | 15 | 16 | | 16 | | | | | | | | | | | 31 | \$250 | \$7,750 |
| 35) Local News | | | 15 | 16 | | 16 | | | | | | | | | | | 31 | \$250 | \$7,750 |
| 36) Local News | | | 15 | 16 | | 16 | | | | | | | | | | | 31 | \$250 | \$7,750 |
| 37) Local News | | | 15 | 16 | | 16 | | | | | | | | | | | 31 | \$250 | \$7,750 |
| 38) Local News | | | 15 | 16 | | 16 | | | | | | | | | | | 31 | \$250 | \$7,750 |
| 39) Local News | | | 15 | 16 | | 16 | | | | | | | | | | | 31 | \$250 | \$7,750 |
| 40) Local News | | | 15 | 16 | | 16 | | | | | | | | | | | 31 | \$250 | \$7,750 |
| 41) Local News | | | 15 | 16 | | 16 | | | | | | | | | | | 31 | \$250 | \$7,750 |
| 42) Local News | | | 15 | 16 | | 16 | | | | | | | | | | | 31 | \$250 | \$7,750 |
| 43) Local News | | | 15 | 16 | | 16 | | | | | | | | | | | 31 | \$250 | \$7,750 |
| 44) Local News | | | 15 | 16 | | 16 | | | | | | | | | | | 31 | \$250 | \$7,750 |
| 45) Local News | | | 15 | 16 | | 16 | | | | | | | | | | | 31 | \$250 | \$7,750 |
| 46) Local News | | | 15 | 16 | | 16 | | | | | | | | | | | 31 | \$250 | \$7,750 |
| 47) Local News | | | 15 | 16 | | 16 | | | | | | | | | | | 31 | \$250 | \$7,750 |
| 48) Local News | | | 15 | 16 | | 16 | | | | | | | | | | | 31 | \$250 | \$7,750 |
| 49) Local News | | | 15 | 16 | | 16 | | | | | | | | | | | 31 | \$250 | \$7,750 |
| 50) Local News | | | 15 | 16 | | 16 | | | | | | | | | | | 31 | \$250 | \$7,750 |
| 51) Local News | | | 15 | 16 | | 16 | | | | | | | | | | | 31 | \$250 | \$7,750 |
| 52) Local News | | | 15 | 16 | | 16 | | | | | | | | | | | 31 | \$250 | \$7,750 |
| 53) Local News | | | 15 | 16 | | 16 | | | | | | | | | | | 31 | \$250 | \$7,750 |
| 54) Local News | | | 15 | 16 | | 16 | | | | | | | | | | | 31 | \$250 | \$7,750 |
| 55) Local News | | | 15 | 16 | | 16 | | | | | | | | | | | 31 | \$250 | \$7,750 |
| 56) Local News | | | 15 | 16 | | 16 | | | | | | | | | | | 31 | \$250 | \$7,750 |
| 57) Local News | | | 15 | 16 | | 16 | | | | | | | | | | | 31 | \$250 | \$7,750 |
| 58) Local News | | | 15 | 16 | | 16 | | | | | | | | | | | 31 | \$250 | \$7,750 |
| 59) Local News | | | 15 | 16 | | 16 | | | | | | | | | | | 31 | \$250 | \$7,750 |
| 60) Local News | | | 15 | 16 | | 16 | | | | | | | | | | | 31 | \$250 | \$7,750 |
| 61) Local News | | | 15 | 16 | | 16 | | | | | | | | | | | 31 | \$250 | \$7,750 |
| 62) Local News | | | 15 | 16 | | 16 | | | | | | | | | | | 31 | \$250 | \$7,750 |
| 63) Local News | | | 15 | 16 | | 16 | | | | | | | | | | | 31 | \$250 | \$7,750 |
| 64) Local News | | | 15 | 16 | | 16 | | | | | | | | | | | 31 | \$250 | \$7,750 |
| 65) Local News | | | 15 | 16 | | 16 | | | | | | | | | | | 31 | \$250 | \$7,750 |
| 66) Local News | | | 15 | 16 | | 16 | | | | | | | | | | | 31 | \$250 | \$7,750 |
| 67) Local News | | | 15 | 16 | | 16 | | | | | | | | | | | 31 | \$250 | \$7,750 |
| 68) Local News | | | 15 | 16 | | 16 | | | | | | | | | | | 31 | \$250 | \$7,750 |
| 69) Local News | | | 15 | 16 | | 16 | | | | | | | | | | | 31 | \$250 | \$7,750 |
| 70) Local News | | | 15 | 16 | | 16 | | | | | | | | | | | 31 | \$250 | \$7,750 |
| 71) Local News | | | 15 | 16 | | 16 | | | | | | | | | | | 31 | \$250 | \$7,750 |
| 72) Local News | | | 15 | 16 | | 16 | | | | | | | | | | | 31 | \$250 | \$7,750 |
| 73) Local News | | | 15 | 16 | | 16 | | | | | | | | | | | 31 | \$250 | \$7,750 |
| 74) Local News | | | 15 | 16 | | 16 | | | | | | | | | | | 31 | \$250 | \$7,750 |
| 75) Local News | | | 15 | 16 | | 16 | | | | | | | | | | | 31 | \$250 | \$7,750 |
| 76) Local News | | | 15 | 16 | | 16 | | | | | | | | | | | 31 | \$250 | \$7,750 |
| 77) Local News | | | 15 | 16 | | 16 | | | | | | | | | | | 31 | \$250 | \$7,750 |
| 78) Local News | | | 15 | 16 | | 16 | | | | | | | | | | | 31 | \$250 | \$7,750 |
| 79) Local News | | | 15 | 16 | | 16 | | | | | | | | | | | 31 | \$250 | \$7,750 |
| 80) Local News | | | 15 | 16 | | 16 | | | | | | | | | | | 31 | \$250 | \$7,750 |
| 81) Local News | | | 15 | 16 | | 16 | | | | | | | | | | | 31 | \$250 | \$7,750 |
| 82) Local News | | | 15 | 16 | | 16 | | | | | | | | | | | 31 | \$250 | \$7,750 |
| 83) Local News | | | 15 | 16 | | 16 | | | | | | | | | | | 31 | \$250 | \$7,750 |
| 84) Local News | | | 15 | 16 | | 16 | | | | | | | | | | | 31 | \$250 | \$7,750 |
| 85) Local News | | | 15 | 16 | | 16 | | | | | | | | | | | 31 | \$250 | \$7,750 |
| 86) Local News | | | 15 | 16 | | | | | | | | | | | | | | | |

BILL NO. _____

ORDINANCE NO. _____

AN ORDINANCE APPROVING AND ACCEPTING CHANGE ORDER NUMBER ONE FOR STORM DRAINAGE IMPROVEMENTS PROJECT AREA #8.

WHEREAS, the City has received change order number 1 from S & A Equipment and Builders for Storm Drainage Improvements Project Area #8; and

WHEREAS, under the change order, the City of Sedalia shall pay the sum and amount of Three Hundred Ninety-one Thousand Nine Hundred Eighty Dollars and Forty-one Cents (\$391,980.41) to S & A Equipment and Builders as more fully described in the proposed change order attached and incorporated by reference herein.

NOW THEREFORE, BE IT ORDAINED BY THE COUNCIL OF THE CITY OF SEDALIA, MISSOURI, as follows:

Section 1. The Council of the City of Sedalia, Missouri hereby approves and accepts change order number 1 by and between the City of Sedalia, Missouri and S & A Equipment and Builders in substantively the same form and content as the change order has been proposed.

Section 2. The Mayor or City Administrator are authorized and directed to execute and the City Clerk is hereby authorized and directed to attest and fix the seal of the City of Sedalia, Missouri on the change order in substantively the same form and content as the change order has been proposed.

Section 3. The City Clerk is hereby directed to file in his office a duplicate or copy of the change order after it has been executed by the parties or their duly authorized representatives.

Section 4. This ordinance shall take effect and be in full force and effect from and after its passage and approval.

Read two times by title, copies of the proposed ordinance having been made available for public inspection prior to the time the bill is under consideration by the Council and passed by the Council of the City of Sedalia, Missouri this 5th day of August 2024.

Presiding Officer of the Council

Approved by the Mayor of said City this 5th day of August 2024.

ATTEST:

Andrew L. Dawson, Mayor

Jason S. Myers
City Clerk



Let's Cross Paths

City of Sedalia

200 S. Osage

Sedalia, MO 65301

(660) 827-3000 www.sedalia.com

To: Kelvin Shaw, City Administrator
Through: Chris Davies, City Engineer
From: Jeremy Stone, Public Works Project Manager
Date: July 12, 2024
Subject: 2021-181D Storm Drainage Improvements Project Area 8-Change Order #1

In 2022, the City applied for grant funds to Missouri Department of Natural Resources for the American Rescue Plan Act (ARPA) for Public Works projects in Stormwater for eight (8) areas in need of storm drainage improvements within City limits. Once all eight (8) projects were bid, the total of all bids awarded were \$535,461.15 below the total grant amount. In working with Missouri Department of Natural Resources and the City Administrator, additional work was identified and approved to further improve storm drainage in the project areas as well as commit the un-used grant funds.

The attached Change Order #1 for the above mentioned project details the additional storm drainage work which would include constructing more curb and gutter along with additional storm piping, and widened roadway with angle parking along Liberty Park Blvd. This project is a part of the Department of Natural Resources ARPA Grant funded stormwater project and this change order has been reviewed and approved by the Department of Natural Resources which is a requirement of this project.

The total cost for Change Order #1 is \$391,980.41, which would bring the total project cost from \$515,914.33 to \$907,894.74.

Thank you for your consideration.

CHANGE ORDER

SHEET NO. (1) OF 1

SEQUENCE NO.: Change Order # 1

TO S&A Equipment and Builders CONTRACTOR

PROJECT NO.: 2021-181D

YOU ARE HEREBY DIRECTED TO MAKE THE FOLLOWING CHANGES FROM THE CONTRACT

1. DESCRIPTION AND REASON FOR CHANGE: (ATTACH SUPPLEMENTAL SHEETS IF REQUIRED)

Additional pavement and sidewalk

2. ESTIMATE OF COST OF WORK AFFECTED BY THIS CHANGE ORDER.

| (A) EST. LINE NO. | (B) ITEM NO. | (C) ITEM DESCRIPTION | (D) UNITS PREVIOUSLY PROVIDED FOR | (E) UNITS TO BE CONSTRUCTED | (F) UNITS OVERRUN, UNDERRUN, CONTINGENT | (G) CONTRACT OR AGREED UNIT PRICE | (H) AMOUNT OF OVERRUN OR PLUS CONTINGENT | (I) AMOUNT OF UNDERRUN OR MINUS CONTINGENT |
|----------------------------|--------------------|-------------------------------------|---|--------------------------------------|---|--|--|--|
| (8) | (9) | (10) | (11) | (12) | (13) | (14) | (15) | (16) |
| 1 | | Mobilization | 1 | 2 | 1 | 1802.90 | 1802.90 | |
| 2 | | Demo and Site Prep | 1 | 2 | 1 | 18257.70 | 18257.70 | |
| 3 | | Traffic Control | 1 | 2 | 1 | 9946.32 | 9946.32 | |
| 4 | | Construction Staking | 1 | 2 | 1 | 4115.88 | 4115.88 | |
| 5 | | Unclassified Excavation | 150 | 325 | 175 | 18.37 | 3214.75 | |
| 6 | | Embankment | 100 | 425 | 325 | 6.47 | 2102.75 | |
| 7 | | Valley Gutter | 0 | 27 | 27 | 279.97 | 7559.19 | |
| 8 | | Type 1 Curb and Gutter | 24 | 1064 | 1040 | 125.62 | 130644.80 | |
| 9 | | Remove and Replace Asphalt Pavement | 126 | 305 | 179 | 102.97 | 18431.63 | |
| 10 | | 4" Asphaltic Surface | 0 | 1878 | 1878 | 68.75 | 129112.50 | |
| 11 | | 6" MoDOT Type 1 Agg Base | 0 | 2110 | 2110 | 12.52 | 26417.20 | |
| 12 | | Concrete Sidewalk | 44 | 60 | 16 | 53.49 | 855.84 | |
| 13 | | Concrete Driveway | 0 | 95 | 95 | 138.27 | 13135.65 | |
| 14 | | Seeding | 800 | 2800 | 2000 | 10.46 | 20920.00 | |
| 15 | | Erosion Control | 1 | 2 | 1 | 5463.30 | 5463.30 | |
| | | | | | | | 391980.41 | |

3. SETTLEMENT FOR COST OF THE ABOVE CHANGE TO BE MADE AT CONTRACT UNIT PRICES, EXCEPT AS NOTED:

| | | |
|---|-----------|-----------|
| 1. CONTRACT AMOUNT | | 515914.33 |
| 2. OVERRUN THIS ORDER (H-I) | 391980.41 | |
| 3. OVERRUN PREVIOUS (LINES 4 ON PREV. ORDERS) | 0.00 | |
| 4. TOTAL OVERRUN TO DATE (2 + 3) | | 391980.41 |
| 5. TOTAL (1 + 4) | | 907894.74 |

4. COMMENTS:

THE TERMS OF SETTLEMENT OUTLINED ABOVE ARE HEREBY AGREED TO.

OWNER'S SIGNATURE

DATE



Digitally signed by Patrick Sapp
Date: 2024.07.11 11:19:59
-05'00'

| | |
|--|---|
| | <p>CONTRACTOR'S SIGNATURE</p> <p>DATE</p> |
|--|---|

BILL NO. _____

ORDINANCE NO. _____

AN ORDINANCE APPROVING AND ACCEPTING CHANGE ORDER NUMBER ONE FOR STORM DRAINAGE IMPROVEMENTS PROJECT AREA #35.

WHEREAS, the City has received change order number 1 from S & A Equipment and Builders for Storm Drainage Improvements Project Area #35; and

WHEREAS, under the change order, the City of Sedalia shall pay the sum and amount of Sixty-Seven Thousand Two Hundred Forty Dollars and Thirty-one Cents (\$67,240.31) to S & A Equipment and Builders as more fully described in the proposed change order attached and incorporated by reference herein.

NOW THEREFORE, BE IT ORDAINED BY THE COUNCIL OF THE CITY OF SEDALIA, MISSOURI, as follows:

Section 1. The Council of the City of Sedalia, Missouri hereby approves and accepts change order number 1 by and between the City of Sedalia, Missouri and S & A Equipment and Builders in substantively the same form and content as the change order has been proposed.

Section 2. The Mayor or City Administrator are authorized and directed to execute and the City Clerk is hereby authorized and directed to attest and fix the seal of the City of Sedalia, Missouri on the change order in substantively the same form and content as the change order has been proposed.

Section 3. The City Clerk is hereby directed to file in his office a duplicate or copy of the change order after it has been executed by the parties or their duly authorized representatives.

Section 4. This ordinance shall take effect and be in full force and effect from and after its passage and approval.

Read two times by title, copies of the proposed ordinance having been made available for public inspection prior to the time the bill is under consideration by the Council and passed by the Council of the City of Sedalia, Missouri this 5th day of August 2024.

Presiding Officer of the Council

Approved by the Mayor of said City this 5th day of August 2024.

ATTEST:

Andrew L. Dawson, Mayor

Jason S. Myers
City Clerk



Let's Cross Paths

City of Sedalia

200 S. Osage

Sedalia, MO 65301

(660) 827-3000 www.sedalia.com

To: Kelvin Shaw, City Administrator
Through: Chris Davies, City Engineer
From: Jeremy Stone, Public Works Project Manager
Date: July 16, 2024
Subject: 2021-181B Storm Drainage Improvements Project Area 35-Change Order #1

In 2022, the City applied for grant funds to Missouri Department of Natural Resources for the American Rescue Plan Act (ARPA) for Public Works projects in Stormwater for eight (8) areas in need of storm drainage improvements within City limits. Once all eight (8) projects were bid, the total of all bids awarded were \$535,461.15 below the total grant amount. In working with Missouri Department of Natural Resources and the City Administrator, additional work was identified and approved to further improve storm drainage in the project areas as well as commit the un-used grant funds.

The attached Change Order #1 for the above mentioned project details the additional storm drainage work which would include constructing and replacing additional storm piping in the area of 13th Street and S. Beacon Ave. This project is a part of the Department of Natural Resources ARPA Grant funded stormwater project and this change order has been reviewed and approved by the Department of Natural Resources which is a requirement of this project.

The total cost for Change Order #1 is \$67,240.31, which would bring the total project cost from \$232,629.83 to \$299,870.14.

Thank you for your consideration.

CHANGE ORDER

SHEET NO. (1) OF 1

SEQUENCE NO.: Change Order # 1

TO S&A Equipment and Builders CONTRACTOR

PROJECT NO.: 2021-181B

YOU ARE HEREBY DIRECTED TO MAKE THE FOLLOWING CHANGES FROM THE CONTRACT

1. DESCRIPTION AND REASON FOR CHANGE: (ATTACH SUPPLEMENTAL SHEETS IF REQUIRED)

Additional Boxes and Pipe Run

2. ESTIMATE OF COST OF WORK AFFECTED BY THIS CHANGE ORDER.

| (A) EST. LINE NO. | (B) ITEM NO. | (C) ITEM DESCRIPTION | (D) UNITS PREVIOUSLY PROVIDED FOR | (E) UNITS TO BE CONSTRUCTED | (F) UNITS OVERRUN, UNDERRUN, CONTINGENT | (G) CONTRACT OR AGREED UNIT PRICE | (H) AMOUNT OF OVERRUN OR PLUS CONTINGENT | (I) AMOUNT OF UNDERRUN OR MINUS CONTINGENT |
|----------------------------|--------------------|-------------------------|---|--------------------------------------|---|--|--|--|
| (8) | (9) | (10) | (11) | (12) | (13) | (14) | (15) | (16) |
| 1 | | Mobilization | 1 | 2 | 1 | 900.63 | 900.63 | |
| 2 | | Demo and Site Prep | 1 | 2 | 1 | 8148.61 | 8148.61 | |
| 3 | | Traffic Control | 1 | 2 | 1 | 1792.89 | 1792.89 | |
| 4 | | Construction Staking | 1 | 2 | 1 | 2349.80 | 2349.80 | |
| 5 | | Type 1 Curb and Gutter | 31 | 39 | 8 | 85.40 | 683.20 | |
| 6 | | Residential Driveway 6" | 56 | 161 | 105 | 135.87 | 14266.35 | |
| 7 | | 5x3 Grated Inlet | 0 | 1 | 1 | 8162.60 | 8162.60 | |
| 8 | | 5' Dia Manhole | 0 | 1 | 1 | 5829.61 | 5829.61 | |
| 9 | | Flowable Fill | 0 | 19 | 19 | 289.61 | 5502.59 | |
| 10 | | 30" HDPE | 298 | 428 | 130 | 83.74 | 10886.20 | |
| 11 | | Sodding | 370 | 420 | 50 | 76.30 | 3815.00 | |
| 12 | | Erosion Control | 1 | 2 | 1 | 4903.19 | 4903.19 | |
| | | | | | | | 67240.31 | |

3. SETTLEMENT FOR COST OF THE ABOVE CHANGE TO BE MADE AT CONTRACT UNIT PRICES, EXCEPT AS NOTED:

| | | |
|---|----------|-----------|
| 1. CONTRACT AMOUNT | | 232629.83 |
| 2. OVERRUN THIS ORDER (H-I) | 67240.31 | |
| 3. OVERRUN PREVIOUS (LINES 4 ON PREV. ORDERS) | | |
| 4. TOTAL OVERRUN TO DATE (2 + 3) | | 67240.31 |
| 5. TOTAL (1 + 4) | | 299870.14 |

4. COMMENTS:

THE TERMS OF SETTLEMENT OUTLINED ABOVE ARE HEREBY AGREED TO.

OWNER'S SIGNATURE DATE
 Digitally signed by Patrick Sapp
 Date: 2024.07.11 08:42:54 -05'00'

CONTRACTOR'S SIGNATURE DATE

BILL NO. _____

ORDINANCE NO. _____

AN ORDINANCE APPROVING AND ACCEPTING CHANGE ORDER NUMBER TWO FOR STORM DRAINAGE IMPROVEMENTS PROJECT AREA #14.

WHEREAS, the City has received change order number 2 from Orr Wyatt Streetscapes for Storm Drainage Improvements Project Area #14; and

WHEREAS, under the change order, the City of Sedalia shall pay the sum and amount of Four Thousand Eight Hundred Fifty-seven Dollars and Twenty-five Cents (\$4,857.25) to Orr Wyatt Streetscapes as more fully described in the proposed change order attached and incorporated by reference herein.

NOW THEREFORE, BE IT ORDAINED BY THE COUNCIL OF THE CITY OF SEDALIA, MISSOURI, as follows:

Section 1. The Council of the City of Sedalia, Missouri hereby approves and accepts change order number 2 by and between the City of Sedalia, Missouri and Orr Wyatt Streetscapes in substantively the same form and content as the change order has been proposed.

Section 2. The Mayor or City Administrator are authorized and directed to execute and the City Clerk is hereby authorized and directed to attest and fix the seal of the City of Sedalia, Missouri on the change order in substantively the same form and content as the change order has been proposed.

Section 3. The City Clerk is hereby directed to file in his office a duplicate or copy of the change order after it has been executed by the parties or their duly authorized representatives.

Section 4. This ordinance shall take effect and be in full force and effect from and after its passage and approval.

Read two times by title, copies of the proposed ordinance having been made available for public inspection prior to the time the bill is under consideration by the Council and passed by the Council of the City of Sedalia, Missouri this 5th day of August 2024.

Presiding Officer of the Council

Approved by the Mayor of said City this 5th day of August 2024.

ATTEST:

Andrew L. Dawson, Mayor

Jason S. Myers
City Clerk



Let's Cross Paths

City of Sedalia

200 S. Osage

Sedalia, MO 65301

(660) 827-3000 www.sedalia.com

To: Kelvin Shaw, City Administrator
Through: Chris Davies, City Engineer
From: Jeremy Stone, Public Works Project Manager
Date: July 30, 2024
Subject: 2021-181A Storm Drainage Improvements Project Area 14-Change Order #2

The Public Works Department has received Change Order #2 request (attached) from Orr Wyatt Streetscapes for the above mentioned project. This project is a part of the Department of Natural Resources ARPA Grant funded stormwater project and this change order has been reviewed and approved by the Department of Natural Resources which is a requirement of this project.

This project was designed to have a section of pipe bored under the MoDOT ROW at S. Center Ave. and Broadway Blvd., however during construction it was found that elevation conflict with the bore and roadway would not allow for this section to be installed. In the reviewing options of the engineered drawings in comparison to existing conditions with the Contractor, Design Engineer and City employees, an alteration of the plans (attached) would be needed for the constructability of the project to work and for drainage to be attainable.

The total cost for Change Order #2 is \$4,857.25, which would bring the total project cost from \$508,120.50 to \$512,977.75.

Thank you for your consideration.

CHANGE ORDER

SHEET NO. (1) OF 2

SEQUENCE NO.: Change Order # 2

TO Orr Wyatt Streetscapes CONTRACTOR

PROJECT NO.: 2021-181A Storm Drainage Improvements
Project Area 14

YOU ARE HEREBY DIRECTED TO MAKE THE FOLLOWING CHANGES FROM THE CONTRACT

1. DESCRIPTION AND REASON FOR CHANGE: (ATTACH SUPPLEMENTAL SHEETS IF REQUIRED)

Bore elevation conflict with existing MoDOT roadway elevation.
Pavement elevation change to promote efficient drainage.

2. ESTIMATE OF COST OF WORK AFFECTED BY THIS CHANGE ORDER.

| (A) EST. LINE NO. | (B) ITEM NO. | (C) ITEM DESCRIPTION | (D) UNITS PREVIOUSLY PROVIDED FOR | (E) UNITS TO BE CONSTRUCTED | (F) UNITS OVERRUN, UNDERRUN, CONTINGENT | (G) CONTRACT OR AGREED UNIT PRICE | (H) AMOUNT OF OVERRUN OR PLUS CONTINGENT | (I) AMOUNT OF UNDERRUN OR MINUS CONTINGENT |
|----------------------------|--------------------|---|---|--------------------------------------|---|--|--|--|
| (8) | (9) | (10) | (11) | (12) | (13) | (14) | (15) | (16) |
| | 18 | 18" HDPE | 228 LF | 0 LF | -228 LF | \$80.00 | | \$18,240.00 |
| | 20.2 | 24" Polypropylene Pipe | 36 LF | 0 LF | -36 LF | \$152.00 | | \$5,472.00 |
| | 22.2 | Jack and Bore 30" Polypropylene Pipe | 55 LF | 0 LF | -55 LF | \$485.00 | | \$26,675.00 |
| | 31 | 30" Polypropylene Pipe | 0 LF | 248 LF | 248 LF | \$172.00 | \$42,656.00 | |
| | 12 | Handicap Ramp NW Corner 50 Hwy & Center -2 9 th & Center +1 NW Corner 7 th & Center +2 | 5 EA | 6 EA | 1 EA | \$2,400.00 | \$2,400.00 | |
| | 7 | Type 1 Curb and Gutter NW Corner 50 Hwy & Center -29 LF NW Corner 7 th & Center +35 LF | 519 LF | 525 LF | 6 LF | \$32.50 | \$195.00 | |
| | 8 | Remove and Replace Asphalt Pavement | 236 SY | 273.75 SY | 37.75 SY | \$163.00 | \$6,153.25 | |
| | 11 | Concrete Sidewalk (4") S of 50 Hwy +260 SF NW Corner of 7 th & Center +250 SF NW Corner 50 Hwy & Center -190 SF | 2,789 SF | 3,109 SF | 320 SF | \$10.00 | \$3,200.00 | |
| | 29 | Demo and Site Prep Sidewalk | 580 SF | 900 SF | 320 SF | \$2.00 | \$640.00 | |
| | | | | | | | \$55,244.25 | \$50,387.00 |

3. SETTLEMENT FOR COST OF THE ABOVE CHANGE TO BE MADE AT CONTRACT UNIT PRICES, EXCEPT AS NOTED:

| | | |
|--|-------------|--------------|
| 1. CONTRACT AMOUNT | | \$488,730.50 |
| 2. OVERRUN THIS ORDER (H-I) | \$4,857.25 | |
| 3. OVERRUN PREVIOUS (LINES 4 ON PREV. ORDERS) | \$19,390.00 | |
| 4. TOTAL OVERRUN TO DATE (2 + 3) | | \$24,247.25 |
| 5. TOTAL (1 + 4) | | \$512,977.75 |

4. COMMENTS:

THE TERMS OF SETTLEMENT OUTLINED ABOVE ARE HEREBY AGREED TO.

OWNER'S SIGNATURE

DATE

JoAnna 'Annie' Jones

7/22/24

CONTRACTOR'S SIGNATURE

DATE

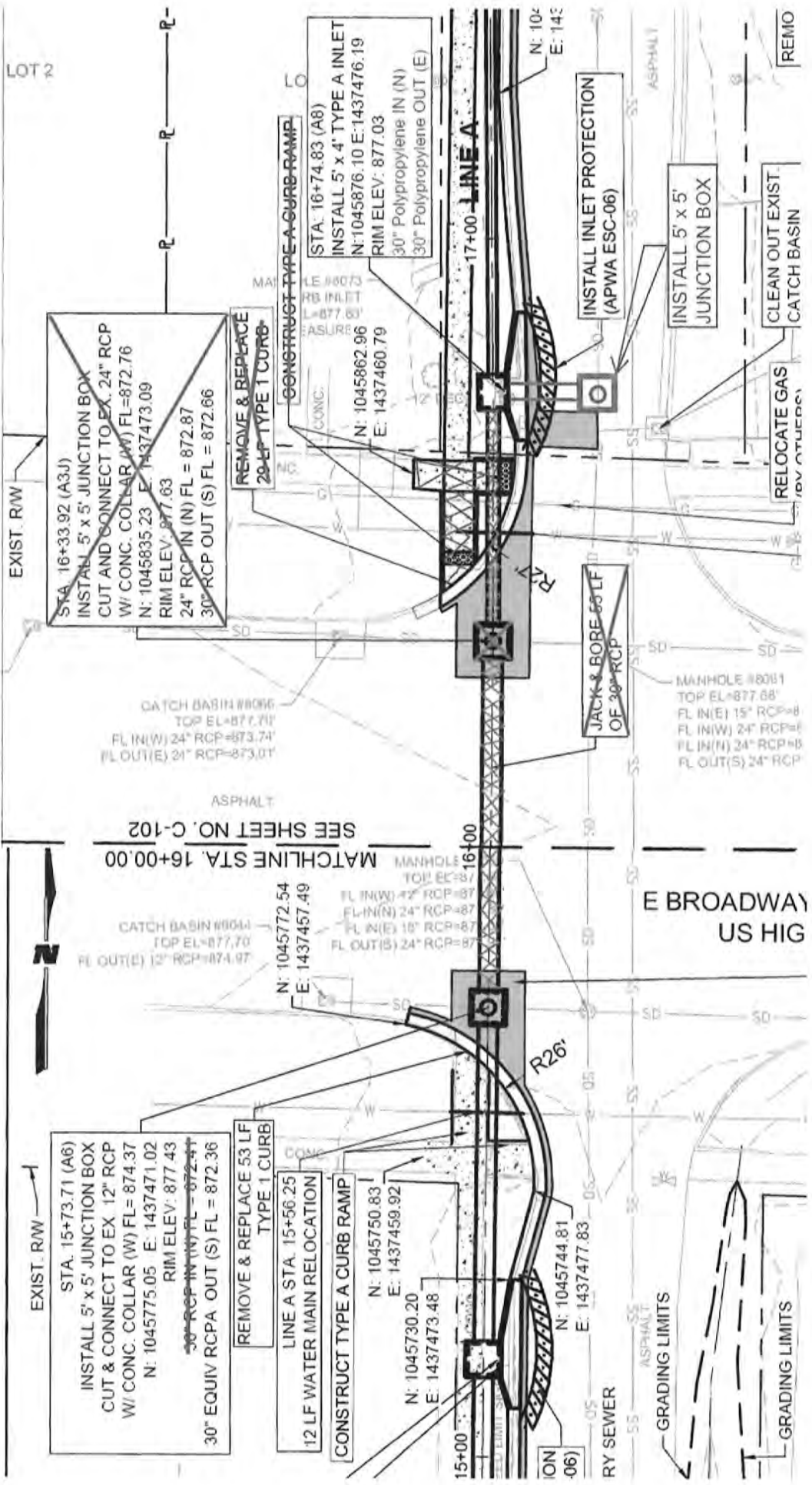

LOT 2

EXIST. RW

EXIST. RW

STA. 16+33.92 (A3J)
 INSTALL 5' x 5' JUNCTION BOX
 CUT AND CONNECT TO EX. 24" RCP
 W/ CONC. COLLAR (W) FL=872.76
 N: 1045835.23 E: 1437473.09
 RIM ELEV: 877.63
 24" RCP IN (N) FL = 872.87
 30" RCP OUT (S) FL = 872.66

REMOVE & REPLACE
 29-LF TYPE 1 CURB

CONSTRUCT TYPE A CURB RAMP

STA: 16+74.83 (A8)
 INSTALL 5' x 4' TYPE A INLET
 N:1045876.10 E:1437476.19
 RIM ELEV: 877.03
 30" Polypropylene IN (N)
 30" Polypropylene OUT (E)

CONC:
 N: 1045862.96
 E: 1437460.79

17+00 LINE A

INSTALL INLET PROTECTION
 (APWA ESC-06)

INSTALL 5' x 5'
 JUNCTION BOX

CLEAN OUT EXIST.
 CATCH BASIN

RELOCATE GAS
 CATCH BASIN

JACK & BORE 55 LF
 OF 30" RCP

MANHOLE #8081
 TOP EL=877.68'
 FL IN(E) 15" RCP=877.68'
 FL IN(W) 24" RCP=877.68'
 FL IN(N) 24" RCP=877.68'
 FL OUT(S) 24" RCP=877.68'

MATCHLINE STA. 16+00.00
 SEE SHEET NO. C-102

CATCH BASIN #8044
 TOP EL=877.70'
 FL OUT(E) 12" RCP=874.97'
 N: 1045772.54
 E: 1437457.49

MANHOLE 16+00
 TOP EL=877.68'
 FL IN(W) 42" RCP=877.68'
 FL IN(N) 24" RCP=877.68'
 FL IN(E) 18" RCP=877.68'
 FL OUT(S) 24" RCP=877.68'

E BROADWAY
 US HIGH



ASPHALT

GRADING LIMITS

GRADING LIMITS

RY SEWER

ION
 -06)

BILL NO. _____

ORDINANCE NO. _____

AN ORDINANCE APPROVING AND ACCEPTING CHANGE ORDER NUMBER ONE FOR STORM DRAINAGE IMPROVEMENTS PROJECT AREA #28.

WHEREAS, the City has received change order number 1 from S & A Equipment and Builders for Storm Drainage Improvements Project Area #28; and

WHEREAS, under the change order, the City of Sedalia shall pay the sum and amount of Forty-four Thousand Six Hundred Ninety-seven Dollars and Ninety-eight Cents (\$44,697.98) to S & A Equipment and Builders as more fully described in the proposed change order attached and incorporated by reference herein.

NOW THEREFORE, BE IT ORDAINED BY THE COUNCIL OF THE CITY OF SEDALIA, MISSOURI, as follows:

Section 1. The Council of the City of Sedalia, Missouri hereby approves and accepts change order number 1 by and between the City of Sedalia, Missouri and S & A Equipment and Builders in substantively the same form and content as the change order has been proposed.

Section 2. The Mayor or City Administrator are authorized and directed to execute and the City Clerk is hereby authorized and directed to attest and fix the seal of the City of Sedalia, Missouri on the change order in substantively the same form and content as the change order has been proposed.

Section 3. The City Clerk is hereby directed to file in his office a duplicate or copy of the change order after it has been executed by the parties or their duly authorized representatives.

Section 4. This ordinance shall take effect and be in full force and effect from and after its passage and approval.

Read two times by title, copies of the proposed ordinance having been made available for public inspection prior to the time the bill is under consideration by the Council and passed by the Council of the City of Sedalia, Missouri this 5th day of August 2024.

Presiding Officer of the Council

Approved by the Mayor of said City this 5th day of August 2024.

ATTEST:

Andrew L. Dawson, Mayor

Jason S. Myers
City Clerk



Let's Cross Paths

City of Sedalia

200 S. Osage

Sedalia, MO 65301

(660) 827-3000 www.sedalia.com

To: Kelvin Shaw, City Administrator
Through: Chris Davies, City Engineer
From: Jeremy Stone, Public Works Project Manager
Date: July 31, 2024
Subject: 2021-181E Storm Drainage Improvements Project Area 28-Change Order #1

The Public Works Department has received Change Order #1 request (attached) from S & A Equipment and Builders, LLC. for the above mentioned project. This project is a part of the Department of Natural Resources ARPA Grant funded stormwater project and this change order has been reviewed and approved by the Department of Natural Resources which is a requirement of this project.

Change Order #1 would allow for replacement of sidewalk within the project area (map attached) in the amount of 11,870 square feet additional to the original contract and would have some cost savings from the substitution of sodding to seed and mulch.

The total cost for Change Order #1 is \$44,697.98, which would bring the total project cost from \$944,883.74 to \$989,581.72.

Thank you for your consideration.

CHANGE ORDER

SHEET NO. (1) OF 1

SEQUENCE NO.: _____ Change Order # 1
 _____ Area 28

TO S&A Equipment and Builders CONTRACTOR

PROJECT NO.: _____

YOU ARE HEREBY DIRECTED TO MAKE THE FOLLOWING CHANGES FROM THE CONTRACT

1. DESCRIPTION AND REASON FOR CHANGE: (ATTACH SUPPLEMENTAL SHEETS IF REQUIRED)
 Underrun sodding and provide seed and mulch use remaining money for additional sidewalk

2. ESTIMATE OF COST OF WORK AFFECTED BY THIS CHANGE ORDER.

| (A) EST. LINE NO. | (B) ITEM NO. | (C) ITEM DESCRIPTION | (D) UNITS PREVIOUSLY PROVIDED FOR | (E) UNITS TO BE CONSTRUCTED | (F) UNITS OVERRUN, UNDERRUN, CONTINGENT | (G) CONTRACT OR AGREED UNIT PRICE | (H) AMOUNT OF OVERRUN OR PLUS CONTINGENT | (I) AMOUNT OF UNDERRUN OR MINUS CONTINGENT |
|----------------------------|--------------------|-------------------------|---|--------------------------------------|---|--|--|--|
| (8) | (9) | (10) | (11) | (12) | (13) | (14) | (15) | (16) |
| 1 | | Sodding | 1700 | 0 | 0 | 25.05 | | -42585.00 |
| 2 | | Seed and Mulch | 1700 | 0 | 1700 | 5.88 | 9996.00 | |
| 3 | | Additional Sidewalk | 2317 | 14187 | 11870 | 6.24 | 74068.80 | |
| 4 | | ADA Ramp | 21 | 23 | 2 | 1609.09 | 3218.18 | |
| | | | | | | | | |
| | | | | | | | | |
| | | | | | | | | |
| | | | | | | | | |
| | | | | | | | | |
| | | | | | | | | |
| | | | | | | | | |
| | | | | | | | | |
| | | | | | | | | |
| | | | | | | | | |
| | | | | | | | | |
| | | | | | | | 87282.98 | 42585.00 |

3. SETTLEMENT FOR COST OF THE ABOVE CHANGE TO BE MADE AT CONTRACT UNIT PRICES, EXCEPT AS NOTED:

| | | |
|---|----------|-----------|
| 1. CONTRACT AMOUNT | | 944883.74 |
| 2. OVERRUN THIS ORDER (H-I) | 44697.98 | |
| 3. OVERRUN PREVIOUS (LINES 4 ON PREV. ORDERS) | 0 | |
| 4. TOTAL OVERRUN TO DATE (2 + 3) | | 44697.98 |
| 5. TOTAL (1 + 4) | | 989581.72 |

4. COMMENTS:

THE TERMS OF SETTLEMENT OUTLINED ABOVE ARE HEREBY AGREED TO.

OWNER'S SIGNATURE _____ DATE _____

CONTRACTOR'S SIGNATURE *PS* Digitally signed by Patrick Sapp
 Date: 2024.07.31 10:20:44
 -05'00'



BILL NO. _____

ORDINANCE NO. _____

AN ORDINANCE APPROVING AND ACCEPTING A QUOTE FOR THE PURCHASE OF A DUMP TRUCK, PLOW AND SPREADER.

WHEREAS, The City of Sedalia, Missouri, has received a quote from Premier Truck Group of Columbia through the State of Missouri's Office of Administration Cooperative Procurement Program under the Missouri Department of Transportation for the purchase of a 2025 Western Star 49X dump truck with Dump Body, Plow and Spreader to be utilized by the Street Division; and

WHEREAS, under the terms of the Quote, the City of Sedalia shall pay the sum and amount of Two Hundred Ninety-seven Thousand Five Hundred Forty-one Dollars (\$297,541.00) to Premier Truck Group of Columbia for said truck, plow and spreader as more fully described in the quote attached to this Ordinance and incorporated by reference herein.

NOW THEREFORE, BE IT ORDAINED BY THE COUNCIL OF THE CITY OF SEDALIA, MISSOURI, as follows:

Section 1. The Council of the City of Sedalia, Missouri, hereby approves and accepts the quote from Premier Truck Group of Columbia in substantively the same form and content as the quote has been proposed.

Section 2. The Mayor or City Administrator are authorized and directed to execute and the City Clerk is hereby authorized and directed to attest and fix the seal of the City of Sedalia, Missouri, on any other documentation, if necessary, in substantively the same form and content as the quote has been proposed.

Section 3. The City Clerk is hereby directed to file in his office a duplicate or copy of the quote and any other subsequent documentation after it has been executed by the parties or their duly authorized representatives.

Section 4. This ordinance shall take effect and be in full force and effect from and after its passage and approval.

Read two times by title, copies of the proposed ordinance having been made available for public inspection prior to the time the bill is under consideration by the Council and passed by the Council of the City of Sedalia, Missouri this 5th day of August, 2024.

Presiding Officer of the Council

Approved by the Mayor of said City this 5th day of August, 2024.

ATTEST:

Andrew L. Dawson, Mayor

Jason S. Myers, City Clerk



Let's Cross Paths

City of Sedalia

200 S. Osage

Sedalia, MO 65301

(660) 827-3000 www.sedalia.com

To: Kelvin Shaw, City Administrator
Through: Matthew Wirt, Assistant City Administrator
From: Justin Bray, Public Works Operations Director
Date: July 30, 2024
Subject: 2025 Western Star 49X Dump Truck with Dump Body, Plow and Spreader

The Public Works Department recommends the City Council approve the purchase of a 2025 Western Star 49X Dump Truck with Dump Body, Plow and Spreader for FY 2025 Budget. The Street Division request to purchase the dump truck from Premier Truck Group of Columbia offered through the State of Missouri's Office of Administration Cooperative Procurement Program under the Missouri Department of Transportation. Bid Solicitation # IFB605CO23002393 pursuant to the City's Financial Management Policy.

"Department heads are encouraged to use cooperative purchasing programs sponsored by the State of Missouri. Cooperative purchasing can prove advantageous to the City by taking advantage of the large quantity purchases made by State Government. Purchases made through these programs have met the requirements of competitive bidding and require the approval of the Department Head and City Administrator. Department heads are encouraged to check with the State regarding cooperative procurement contracts in effect prior to making any large purchase."

The dump truck was presented at the strategic budget planning session and council prioritized it to be in the FY 2025 budget for \$350,000.00

The total cost of the 2025 Western Star 49X, including dump Body, plow and spreader is \$297,541.00. This is a saving of \$52,459.00.

The public works department will be replacing dump truck #210 a 1998 freightliner FL70, this dump truck has a broken frame and will be sold on Govdeals as is.

Thank you for your consideration of this request.



Purchase Agreement and Acknowledgement

Ver 4/2023

Premier Truck Group of Columbia

1660 Jade Road
Columbia MO 65201
Phone: (573) 886-0188

Department: NEW
Contract Date: 07/30/2024
Deal Packet: DE-54079
Branch: 809
Salesperson: Mike Talleur

Bill To: PROS-034686
CITY OF SEDALIA PUBLIC WORKS
901 E 3RD ST
SEDALIA MO 65301-4661
P:(660) 826-3357

Ship To:
CITY OF SEDALIA PUBLIC WORKS
901 E 3RD ST
SEDALIA, MO 65301-4661

| | | | | |
|-----------|--------|--|--------------------|---------------------|
| Stock#:NA | VIN:NA | New 2025 WESTERN STAR 49X DUMP BODY , PLOW , SPREADER | Price: | \$151,834.00 |
| | | | | \$145,307.00 |
| | | | Per Unit: | \$297,141.00 |
| | | | Total Price | \$297,141.00 |
| | | | Documentary Fee | \$400.00 |
| | | | Total | \$297,541.00 |
| | | | Net Total | \$297,541.00 |

CITY OF SEDALIA REQUESTED SPEC IN LIEU OF MODOT SPEC , SOLICITATION # IFB605CO23002393. MODOT DISCOUNT APPLIED

EXTENDED WARRANTY AVAILABLE FOR AN ADDITIONAL COST

EW4: DD13H VOC \$0 DED 5 YEARS/200,000 MILES - ADD \$3,990

TOWING: 5 YEARS/UNLIMITED MILES/KM EXTENDED \$1200 CAP - ADD \$1,810

A DOCUMENTARY FEE IS NOT AN OFFICIAL FEE. A DOCUMENTARY FEE IS NOT REQUIRED BY LAW, BUT MAY BE CHARGED TO PURCHASERS FOR HANDLING DOCUMENTS RELATING TO THE SALE. A DOCUMENTARY FEE MAY NOT EXCEED A REASONABLE AMOUNT AGREED TO BY THE PARTIES. THIS NOTICE IS REQUIRED BY LAW.

The Dealer's Inventory Tax charge is intended to reimburse the Dealer for ad valorem taxes on its motor vehicle inventory. The charge, which is paid by the Dealer to the county tax assessor-collector, is not a tax imposed on a Purchaser by the government, and is not required to be charged by the Dealer to the Purchaser.

THE UNDERSIGNED PURCHASER HEREBY OFFERS TO PURCHASE FROM YOU, THE DEALER, FOR THE STATED PRICE THE NEW VEHICLE(S) DESCRIBED HEREIN, SUBJECT TO THE TERMS AND CONDITIONS SET FORTH IN THIS PURCHASE AGREEMENT AND ACKNOWLEDGEMENT.

IMPORTANT: Also additional Terms and Conditions attached in this agreement.

EXECUTED BY THE PARTIES IN DUPLICATE, ONE COPY OF WHICH HAS BEEN DELIVERED TO THE PURCHASER WHO ACKNOWLEDGES AND ACCEPTS, SUBJECT TO LIMITED WARRANTY, WARRANTY DISCLAIMER AND LIMITATIONS OF LIABILITY AS SHOWN ON THE NEW VEHICLE OWNER'S WARRANTY REGISTRATION FORM.

Your business is always appreciated!

PURCHASER'S SIGNATURE TITLE DATE

ACCEPTED BY

CO-SIGNER'S SIGNATURE TITLE DATE

AUTHORIZED SIGNATURE

VENUE: It is agreed that this agreement is entered into in the State of Texas and is governed by the laws of the State of Texas.

Prepared for:
JUSTIN BRAY
SEDALIA CITY OF
200 S OSAGE AVE
SEDALIA, MO 65301
Phone: 660 827 3000

Prepared by:
Mike Talleur
PREMIER TRUCK GROUP OF
COLUMBIA
1660 JADE ROAD
COLUMBIA, MO 65201
Phone: 1-573-886-0429

A proposal for
SEDALIA CITY OF

Prepared by
PREMIER TRUCK GROUP OF COLUMBIA
Mike Talleur

Jul 30, 2024

Western Star 49X



Components shown may not reflect all spec'd options and are not to scale

Prepared for:
 JUSTIN BRAY
 SEDALIA CITY OF
 200 S OSAGE AVE
 SEDALIA, MO 65301
 Phone: 660 827 3000

Prepared by:
 Mike Talleur
 PREMIER TRUCK GROUP OF
 COLUMBIA
 1660 JADE ROAD
 COLUMBIA, MO 65201
 Phone: 1-573-886-0429

S P E C I F I C A T I O N P R O P O S A L

| Description | Weight Front | Weight Rear |
|---|-----------------|----------------|
| Price Level | | |
| WST 47X/49X PRL-28X (EFF:MY25 ORDERS) | | |
| Data Version | | |
| SPECPRO21 DATA RELEASE VER 002 | | |
| Vehicle Configuration | | |
| WESTERN STAR 49X | 9,175 | 6,500 |
| 2025 MODEL YEAR SPECIFIED | | |
| SET BACK AXLE - TRUCK | | |
| TRAILER TOWING PROVISION AT END OF FRAME WITH SAE J560, WITHOUT END OF FRAME AIR CONNECTIONS | 15 | 15 |
| LH PRIMARY STEERING LOCATION | | |
| General Service | | |
| TRUCK CONFIGURATION | | |
| DOMICILED, USA (EXCLUDING CALIFORNIA AND CARB OPT-IN STATES) | | |
| EPA EMISSIONS CERTIFICATION FOR REGISTRATION IN EPA OR ACT STATES - EPA CLEAN IDLE (INCLUDES 6X4 INCH LABEL ON LOWER FORWARD OF DRIVER DOOR) | | |
| CONSTRUCTION SERVICE | | |
| CONSTRUCTION BUSINESS SEGMENT | | |
| DIRT/SAND/ROCK COMMODITY | | |
| TERRAIN/DUTY: 100% (ALL) OF THE TIME, IN TRANSIT, IS SPENT ON PAVED ROADS | | |
| MAXIMUM 8% EXPECTED GRADE | | |
| SMOOTH CONCRETE OR ASPHALT PAVEMENT - MOST SEVERE IN-TRANSIT (BETWEEN SITES) ROAD SURFACE | | |
| WESTERN STAR SEVERE SERVICE WARRANTY | | |
| EXPECTED FRONT AXLE(S) LOAD : 18000.0 lbs | | |

Prepared for:
 JUSTIN BRAY
 SEDALIA CITY OF
 200 S OSAGE AVE
 SEDALIA, MO 65301
 Phone: 660 827 3000

Prepared by:
 Mike Talleur
 PREMIER TRUCK GROUP OF
 COLUMBIA
 1660 JADE ROAD
 COLUMBIA, MO 65201
 Phone: 1-573-886-0429

| Description | Weight Front | Weight Rear |
|---|--------------|-------------|
| EXPECTED REAR DRIVE AXLE(S) LOAD : 46000.0 lbs | | |
| EXPECTED PUSHER AXLE(S) LOAD : 13500.0 lbs | | |
| EXPECTED GROSS VEHICLE WEIGHT CAPACITY : 77500.0 lbs | | |
| Truck Service | | |
| FRONT PLOW/END DUMP BODY HENDERSON | | |
| Engine | | |
| DETROIT DD13 GEN 5 12.8L 505 HP @ 1625 RPM, 1900 GOV RPM, 1850 LB/FT @ 975 RPM | -280 | -10 |
| Electronic Parameters | | |
| 75 MPH ROAD SPEED LIMIT | | |
| CRUISE CONTROL SPEED LIMIT SAME AS ROAD SPEED LIMIT, WITH AUTO RESUME AFTER SHIFT | | |
| FLEET MANAGEMENT - DAILY ENGINE USAGE ENABLED | | |
| 5 MINUTES IDLE SHUTDOWN WITH CLUTCH AND SERVICE BRAKE OVERRIDE | | |
| PTO MODE ENGINE RPM LIMIT - 1600 RPM | | |
| PTO RPM CONTROL WITH STEERING WHEEL SWITCHES | | |
| PTO MODE RPM INCREMENT - 25 RPM | | |
| PTO GOVERNOR RAMP RATE - 25 RPM PER SECOND | | |
| ONE DASH PTO SPEED SWITCH, WITH ONE TEM PTO SPEED | | |
| PTO SPEED 1 SETTING - 600 RPM | | |
| ENGINE BRAKE WITH GLOBAL CRUISE CONTROL ENABLED | | |
| PTO MINIMUM RPM - 600 | | |
| ENABLE AUTO ENGINE RPM ELEVATE FOR EXTENDED IDLE | | |
| MAINTENANCE SYSTEM WITH NO POP-UPS AND NO MENU IN CLUSTER | | |
| PTO 1, DASH SWITCH, ENGAGE BEFORE DRIVING | | |
| Engine Equipment | | |
| EPA 2010/GHG 2024 CONFIGURATION | | |
| STANDARD OIL PAN | | |

Prepared for:
 JUSTIN BRAY
 SEDALIA CITY OF
 200 S OSAGE AVE
 SEDALIA, MO 65301
 Phone: 660 827 3000

Prepared by:
 Mike Talleur
 PREMIER TRUCK GROUP OF
 COLUMBIA
 1660 JADE ROAD
 COLUMBIA, MO 65201
 Phone: 1-573-886-0429

| Description | Weight Front | Weight Rear |
|--|--------------|-------------|
| ENGINE MOUNTED OIL CHECK AND FILL | | |
| SIDE OF HOOD AIR INTAKE WITH ENGINE MOUNTED AIR CLEANER | | |
| LN 12V 170 AMP AVI 160 PAD MOUNT ALTERNATOR | | |
| (3) DTNA GENUINE, HIGH TEMP AGM STARTING AND CYCLING, MIN 2775CCA, 570RC, THREADED STUD BATTERIES | | |
| PASSENGER SEAT BATTERY BOX VENTED TO OUTSIDE OF CAB | | |
| BATTERY BOX MOUNTED UNDER PASSENGER SEAT | | |
| WIRE GROUND RETURN FOR BATTERY CABLES WITH ADDITIONAL FRAME GROUND RETURN | | |
| PLASTIC BATTERY BOX COVER | | |
| POSITIVE LOAD DISCONNECT WITH CAB MOUNTED CONTROL SWITCH MOUNTED OUTBOARD DRIVER SEAT | 2 | |
| POSITIVE AND NEGATIVE POSTS FOR JUMPSTART LOCATED ON FRAME NEXT TO STARTER | 2 | |
| BW MODEL FE-921 19.0 CFM SINGLE CYLINDER AIR COMPRESSOR WITH SAFETY VALVE | | |
| ELECTRONIC ENGINE INTEGRAL SHUTDOWN PROTECTION SYSTEM | | |
| JACOBS COMPRESSION BRAKE | | |
| RH OUTBOARD UNDER STEP MOUNTED HORIZONTAL AFTERTREATMENT SYSTEM ASSEMBLY WITH RH B-PILLAR MOUNTED VERTICAL TAILPIPE | | |
| ENGINE AFTERTREATMENT DEVICE, AUTOMATIC OVER THE ROAD ACTIVE REGENERATION AND VIRTUAL REGENERATION REQUEST SWITCH IN CLUSTER AND DASH MOUNTED INHIBIT SWITCH | | |
| 11 FOOT 06 INCH (138 INCH+0/-5.9 INCH) EXHAUST SYSTEM HEIGHT | | |
| STANDARD CURVE BRIGHT UPPER STACK(S) | | |
| RH CURVED VERTICAL TAILPIPE B-PILLAR MOUNTED ROUTED FROM STEP | | |
| 8 GALLON DIESEL EXHAUST FLUID TANK UNPOLISHED ALUMINUM WST DIESEL EXHAUST FLUID TANK COVER | | |
| LH HEAVY DUTY STANDARD DIESEL EXHAUST FLUID TANK LOCATION | | |

Prepared for:
 JUSTIN BRAY
 SEDALIA CITY OF
 200 S OSAGE AVE
 SEDALIA, MO 65301
 Phone: 660 827 3000

Prepared by:
 Mike Talleur
 PREMIER TRUCK GROUP OF
 COLUMBIA
 1660 JADE ROAD
 COLUMBIA, MO 65201
 Phone: 1-573-886-0429

| Description | Weight Front | Weight Rear |
|--|-----------------|----------------|
| STANDARD DIESEL EXHAUST FLUID TANK CAP | | |
| STAINLESS STEEL AFTERTREATMENT DEVICE/MUFFLER/TAILPIPE SHIELD | | |
| ELECTRONICALLY CONTROLLED VARIABLE SPEED VISCOUS FAN DRIVE | | |
| AUTOMATIC FAN CONTROL WITHOUT DASH SWITCH, NON ENGINE MOUNTED | | |
| DAVCO 385 FUEL/WATER SEPARATOR WITH ESOC AND 12 VOLT PREHEATER | 10 | |
| DDC SUPPLIED ENGINE MOUNTED FUEL FILTER/FUEL WATER SEPARATOR WITH WATER-IN-FUEL INDICATOR | | |
| FULL FLOW OIL FILTER | | |
| 1400 SQUARE INCH VOCATIONAL RADIATOR | | |
| ANTIFREEZE TO -34F, OAT (NITRITE AND SILICATE FREE) EXTENDED LIFE COOLANT | | |
| GATES BLUE STRIPE COOLANT HOSES OR EQUIVALENT | | |
| STANDARD CHARGE AIR COOLER PLUMBING | | |
| HDEP FIXED RATIO COOLANT PUMP AND RADIATOR DRAIN VALVE | | |
| LOWER RADIATOR GUARD | | |
| PHILLIPS-TEMRO 1500 WATT/115 VOLT BLOCK HEATER | 4 | |
| CHROME ENGINE HEATER RECEPTACLE MOUNTED UNDER LH DOOR | | |
| NO AIR INTAKE WARMER | -10 | |
| DELCO 12V MOD 3.175-39MT+ STARTER WITH ENGINE ECU SOFTWARE PROTECTION AND INTEGRATED MAGNETIC SWITCH | -45 | |

Transmission

DT12-1850-OV VOCATIONAL 12-SPEED
 OVERDRIVE AUTOMATED MANUAL
 TRANSMISSION

Transmission Equipment

DT12 PERFORMANCE PKG: ECONOMY,
 PERFORMANCE AND OFFROAD, WITH ICU
 CONTROL MENUS, WITH KICKDOWN,
 PERSISTENT
 12 FORWARD GEARS SELECTABLE DT12
 MANUAL MODE
 ROCK FREE MODE

Prepared for:
 JUSTIN BRAY
 SEDALIA CITY OF
 200 S OSAGE AVE
 SEDALIA, MO 65301
 Phone: 660 827 3000

Prepared by:
 Mike Talleur
 PREMIER TRUCK GROUP OF
 COLUMBIA
 1660 JADE ROAD
 COLUMBIA, MO 65201
 Phone: 1-573-886-0429

| Description | Weight Front | Weight Rear |
|---|--------------|-------------|
| MAXIMUM OUTPUT SPEED FOR PTO ENGAGEMENT 25 RPM | | |
| DT12 REAR PTO LOW SPEED RATIO | | |
| QUICKFIT BODY LIGHTING CONNECTOR UNDER CAB, WITH CAP | | |
| NO AUX/ACC TRANSMISSION WIRING | | |
| DETROIT HEAVY DUTY AUTOMATED MANUAL TRANSMISSION CLUTCH | | |
| ALUMINUM CLUTCH HOUSING | | |
| DT12 REAR MOUNTED PTO 1:1 FOR CUSTOMER INSTALLED HYDRAULIC PUMP | 25 | |
| PTO MOUNTING, REAR OF MAIN TRANSMISSION DETROIT & EATON FULLER | | |
| MAGNETIC PLUGS, ENGINE DRAIN, TRANSMISSION DRAIN, AXLE(S) FILL AND DRAIN | | |
| HEAVY DUTY ELECTRONIC TRANSMISSION SHIFT CONTROL, COLUMN MOUNTED | | |
| AIR TO OIL TRANSMISSION COOLER | 15 | |
| SYNTHETIC TRANSMISSION LUBE | | |
| Front Axle and Equipment | | |
| DETROIT DA-F-18.0-5 18,000# FL1 71.0 KPI/3.74 DROP SINGLE FRONT AXLE | 90 | |
| CONMET PRESET PLUS PREMIUM ALUMINUM FRONT HUBS | | |
| MERITOR 16.5X6 Q+ CAST SPIDER CAM FRONT BRAKES, DOUBLE ANCHOR, FABRICATED SHOES | 10 | |
| NON-ASBESTOS FRONT BRAKE LINING | | |
| MERITOR STEELLITE X30 FRONT BRAKE DRUMS | -30 | |
| FRONT BRAKE DUST SHIELDS | | |
| FRONT OIL SEALS | | |
| VENTED FRONT HUB CAPS WITH WINDOW, CENTER AND SIDE PLUGS - OIL | | |
| HALDEX AUTOMATIC FRONT SLACK ADJUSTERS | | |
| DUAL POWER STEERING GEARS, BENDIX 16-20K | 80 | |
| 4 QUART POWER STEERING RESERVOIR | | |
| OIL/AIR POWER STEERING COOLER | | |
| CURRENT AVAILABLE SYNTHETIC 75W-90 FRONT AXLE LUBE | | |

Prepared for:
 JUSTIN BRAY
 SEDALIA CITY OF
 200 S OSAGE AVE
 SEDALIA, MO 65301
 Phone: 660 827 3000

Prepared by:
 Mike Talleur
 PREMIER TRUCK GROUP OF
 COLUMBIA
 1660 JADE ROAD
 COLUMBIA, MO 65201
 Phone: 1-573-886-0429

| Description | Weight Front | Weight Rear |
|---|--------------|-------------|
| Front Suspension | | |
| 18,000# TAPERLEAF FRONT SUSPENSION | 145 | |
| MAINTENANCE FREE RUBBER BUSHINGS - FRONT SUSPENSION | | |
| FRONT SHOCK ABSORBERS | | |
| Rear Axle and Equipment | | |
| CUMMINS-MERITOR RT-46-160 46,000# R-SERIES DUALTRAC 74-77 INCH INTERMEDIATE TRACK TANDEM REAR AXLE | | 515 |
| CONMET PRESET PLUS PREMIUM ALUMINUM REAR HUBS | | |
| 3.07 REAR AXLE RATIO | | |
| IRON REAR AXLE CARRIER WITH STANDARD AXLE HOUSING | | |
| SPL250 HT XL DANA SPICER MAIN DRIVELINE | | |
| SPL170 XL DANA SPICER INTERAXLE DRIVELINE WITH HALF ROUND YOKES | | 10 |
| DRIVER CONTROLLED TRACTION DIFFERENTIAL - BOTH TANDEM REAR AXLES | | 30 |
| (1) INTERAXLE LOCK VALVE, (1) DRIVER CONTROLLED DIFFERENTIAL LOCK FORWARD-REAR AND REAR-REAR AXLE VALVE | | |
| INDICATOR LIGHT FOR EACH INTERAXLE LOCKOUT SWITCH | | |
| INDICATOR LIGHT AND BUZZER FOR EACH DIFFERENTIAL LOCKOUT SWITCH | | |
| MERITOR 16.5X8.62 Q+ CAST SPIDER CAM REAR BRAKES, DOUBLE ANCHOR, FABRICATED SHOES | | |
| NON-ASBESTOS REAR BRAKE LINING | | |
| BRAKE CAMS AND CHAMBERS ON FORWARD SIDE OF DRIVE AXLE(S) | | |
| CONMET CAST IRON REAR BRAKE DRUMS | | |
| REAR BRAKE DUST SHIELDS | | 5 |
| REAR OIL SEALS | | |
| BENDIX EVERSURE LONGSTROKE 2-DRIVE AXLES SPRING PARKING CHAMBERS | | |
| HALDEX AUTOMATIC REAR SLACK ADJUSTERS | | |
| CURRENT AVAILABLE SYNTHETIC 75W-90 REAR AXLE LUBE | | |
| STANDARD REAR AXLE BREATHER(S) | | |

Rear Suspension

Prepared for:
 JUSTIN BRAY
 SEDALIA CITY OF
 200 S OSAGE AVE
 SEDALIA, MO 65301
 Phone: 660 827 3000

Prepared by:
 Mike Talleur
 PREMIER TRUCK GROUP OF
 COLUMBIA
 1660 JADE ROAD
 COLUMBIA, MO 65201
 Phone: 1-573-886-0429

| Description | Weight Front | Weight Rear |
|---|--------------|-------------|
| TUFTRAC GEN2 46,000# REAR SPRING SUSPENSION | | 560 |
| 9.5 INCH NOMINAL RIDE HEIGHT (460MM GLOBAL REFERENCE HEIGHT) | | |
| AXLE CLAMPING GROUP | | |
| 55 INCH AXLE SPACING | | |
| FORE/AFT AND TRANSVERSE CONTROL RODS | | |
| REAR SHOCK ABSORBERS - TWO AXLES (TANDEM) | | 40 |
| Pusher / Tag Equipment | | |
| HENDRICKSON EX13 COMP 13,500# AIR LIFT STEERABLE PUSHER SUSPENSION, FF1 AXLE | 660 | 660 |
| HENDRICKSON EX13 COMP 13,500# FF1 STEERABLE INTEGRAL PUSHER AXLE | | |
| CONMET PRESET PLUS PREMIUM IRON PUSHER/TAG HUBS | | |
| (1) DASH VALVE AND (1) GAUGE FOR SINGLE LIFT AXLE | | |
| LIFT AXLE WIRING, LIFT IN REVERSE, WITH LAST STATE RETENTION WITH IGNITION OFF | | |
| (1)REGULATOR MOUNTED ON CHASSIS FOR SINGLE LIFT AXLE | 10 | |
| HENDRICKSON 15X4 CAM PUSHER/TAG BRAKES, DOUBLE ANCHOR, FABRICATED SHOES | | |
| NON-ASBESTOS PUSHER/TAG BRAKE LINING | | |
| CONMET CAST IRON PUSHER/TAG BRAKE DRUMS | | |
| PUSHER/TAG BRAKE DUST SHIELDS | | 5 |
| PUSHER/TAG OIL SEALS | | |
| VENTED PUSHER/TAG HUB CAPS WITH WINDOW, CENTER AND SIDE PLUGS - OIL | | |
| HALDEX LONGSTROKE PUSHER/TAG AXLE SERVICE CHAMBERS | | |
| HALDEX AUTOMATIC PUSHER/TAG SLACK ADJUSTERS | | |
| HENDRICKSON EX13 COMP 13,500# AIR LIFT STEERABLE PUSHER SUSPENSION | | |
| 55 INCH AXLE SPACING PUSHER/TAG | | |
| Brake System | | |
| WABCO 6S/6M ABS WITH HILL START AID AND TRACTION CONTROL WITH ATC SHUT OFF SWITCH | | |

Prepared for:
 JUSTIN BRAY
 SEDALIA CITY OF
 200 S OSAGE AVE
 SEDALIA, MO 65301
 Phone: 660 827 3000

Prepared by:
 Mike Talleur
 PREMIER TRUCK GROUP OF
 COLUMBIA
 1660 JADE ROAD
 COLUMBIA, MO 65201
 Phone: 1-573-886-0429

| Description | Weight Front | Weight Rear |
|--|--------------|-------------|
| REINFORCED NYLON, FABRIC BRAID AND WIRE BRAID CHASSIS AIR LINES | | |
| (2) RELAY VALVES; ONE 5-8 PSI FOR TANDEM AXLE AND ONE 3-4.5 PSI CRACK FOR PUSHER/TAG | | |
| WABCO SYSTEM SAVER 1200 HEATED AIR DRYER WITH PRESSURE CONTROL VALVE | | |
| WABCO OIL COALESCING FILTER FOR AIR DRYER | | |
| AIR DRYER MOUNTED UNDER HOOD | | |
| STEEL AIR BRAKE RESERVOIRS | | |
| PULL CABLES ON ALL AIR RESERVOIR(S) | | |
| Trailer Connections | | |
| PRIMARY CONNECTOR/RECEPTACLE WIRED FOR SEPARATE STOP/TURN, ABS CENTER PIN POWERED THROUGH IGNITION | | |
| SAE J560 7-WAY PRIMARY TRAILER CABLE RECEPTACLE MOUNTED END OF FRAME | | |
| NO TRAILER ELECTRICAL CABLE | -10 | |
| Wheelbase & Frame | | |
| 5625MM (221 INCH) WHEELBASE | | |
| 11.0MM X 85.0MM X 287.0MM STEEL FRAME (0.43X3.35X11.30 INCH) 120 KSI | 270 | 210 |
| TEM TO EVALUATE AND INSTALL FRAME RAIL REINFORCEMENT AS NEEDED FOR FRONT FRAME MOUNTED EQUIPMENT | | |
| 1650MM (65 INCH) REAR FRAME OVERHANG | | |
| FRAME OVERHANG RANGE: 61 INCH TO 70 INCH | -30 | 80 |
| 24 INCH INTEGRAL FRONT FRAME EXTENSION | 100 | |
| CALC'D BACK OF CAB TO REAR SUSP C/L (CA) : 146.46 in | | |
| CALC'D FRAME LENGTH - OVERALL : 355.39 in | | |
| FRAME HEIGHT TOP FRONT UNLADEN : 43.63 in | | |
| FRAME HEIGHT TOP FRONT LADEN : 40.74 in | | |
| FRAME HEIGHT TOP REAR UNLADEN : 43.52 in | | |
| FRAME HEIGHT TOP REAR LADEN : 40.81 in | | |
| SQUARE END OF FRAME | | |
| STANDARD WEIGHT ENGINE CROSSMEMBER | | |
| HEAVY DUTY BACK OF TRANSMISSION CROSSMEMBER | 10 | |

Prepared for:
 JUSTIN BRAY
 SEDALIA CITY OF
 200 S OSAGE AVE
 SEDALIA, MO 65301
 Phone: 660 827 3000

Prepared by:
 Mike Talleur
 PREMIER TRUCK GROUP OF
 COLUMBIA
 1660 JADE ROAD
 COLUMBIA, MO 65201
 Phone: 1-573-886-0429

| Description | Weight Front | Weight Rear |
|--|--------------|-------------|
| STANDARD CAST ALUMINUM MIDSHIP | | |
| STANDARD CAST ALUMINUM REARMOST CROSSMEMBER | | |
| STANDARD SUSPENSION CROSSMEMBER | | 20 |
| CAST ALUMINUM REAR SUSPENSION CROSSMEMBER | | |
| Chassis Equipment | | |
| UNPOLISHED ALUMINUM WST EQUIPMENT COVERS | | |
| NO LH OR RH BACK OF CAB ACCESS | -10 | -10 |
| OMIT FRONT BUMPER, CUSTOMER INSTALLED SPECIAL BUMPER, DOES NOT COMPLY WITH FMCSR 393.203 | -60 | |
| NO FRONT TOW HOOKS | -15 | |
| NO LICENSE PLATE MOUNTING | | |
| CLASS 10.9 THREADED METRIC FASTENERS | | |
| EXTERIOR HARNESSES WRAPPED IN ABRASION TAPE | | |
| UPFIT ROUTING AND CLIPPING BRACKET, LH, BOC TO SUSPENSION, UPPER & LOWER SUPPORTS | | |
| UPFIT ROUTING AND CLIPPING BRACKET, RH, BOC TO SUSPENSION, UPPER & LOWER SUPPORTS | | |
| Fuel Tanks | | |
| 100 GALLON/378 LITER ALUMINUM FUEL TANK - LH | -15 | -10 |
| 25 INCH DIAMETER FUEL TANK(S) | | |
| PLAIN ALUMINUM/PAINTED STEEL FUEL/HYDRAULIC TANK(S) WITH PAINTED BANDS | | |
| FUEL TANK(S) FORWARD | | |
| POLISHED STEP FINISH | | |
| FUEL TANK CAP(S) | | |
| EQUIFLO INBOARD FUEL SYSTEM | | |
| HIGH TEMPERATURE REINFORCED NYLON FUEL LINE | | |
| Tires | | |
| MICHELIN X WORKS Z 315/80R22.5 20 PLY RADIAL FRONT TIRES | 100 | |
| MICHELIN X WORKS XDY 315/80R22.5 20 PLY RADIAL REAR TIRES | | 464 |

Prepared for:
 JUSTIN BRAY
 SEDALIA CITY OF
 200 S OSAGE AVE
 SEDALIA, MO 65301
 Phone: 660 827 3000

Prepared by:
 Mike Talleur
 PREMIER TRUCK GROUP OF
 COLUMBIA
 1660 JADE ROAD
 COLUMBIA, MO 65201
 Phone: 1-573-886-0429

| Description | Weight Front | Weight Rear |
|---|--------------|-------------|
| CONTINENTAL HS3+ ECO PLUS 295/75R22.5 16 PLY RADIAL PUSHER/TAG TIRES | | 8 |
| Wheels | | |
| ALCOA ULTRA ONE 89U63X 22.5X9.00 10-HUB PILOT 3.12 INSET 10-HD ALUMINUM FRONT WHEELS | -44 | |
| ALCOA ULTRA ONE 89U64X 22.5X9.00 10-HUB PILOT 5.99 INSET ALUMINUM REAR WHEELS | | -112 |
| ALCOA ULA18X 22.5X8.25 5.81 INSET 10-HUB PILOT ALUMINUM DISC PUSHER/TAG WHEELS | | -62 |
| FRONT WHEEL MOUNTING NUTS | | |
| REAR WHEEL MOUNTING NUTS | | |
| PUSHER/TAG WHEEL MTG NUTS | | |
| Cab Exterior | | |
| 121 INCH BBC ALUMINUM CONVENTIONAL CAB STAINLESS STEEL CAB ACCENT MOLDING FRONT FENDERS INTERIOR GRAB HANDLES WITH ADDED LOWER LH AND RH A PILLAR GRAB HANDLES AND LH AND RH EXTERIOR NON-SLIP GRAB HANDLES BRIGHT HOOD MOUNTED AIR INTAKE GRILLE, BLACK SCREEN, WITH LED ACCENT LIGHTS X-SERIES STEEL REINFORCED ALUMINUM CAB X-SERIES VOCATIONAL HOOD HOOD OPENING ASSIST WITH LOCKING STRUT WESTERN STAR NAMEPLATES DUAL HADLEY SD-978 26 INCH RECTANGULAR AIR HORNS SINGLE ELECTRIC HORN REAR LICENSE PLATE MOUNT END OF FRAME DUAL STAGE INTELLIGENT LED HEADLIGHTS WITH HEATED LENS SYSTEM VISOR MOUNTED LED MARKER LIGHTS WIRING AND SWITCH FOR CUSTOMER FURNISHED SNOW PLOW LAMPS WITH DUAL CONNECTIONS AT BUMPER DAYTIME RUNNING LIGHTS INTEGRAL LED STOP/TAIL/BACKUP LIGHTS WITH 7 EXTRA FEET OF WIRE MOUNTED END OF FRAME LED SIDE TURN SIGNAL | | 5 |

Prepared for:
 JUSTIN BRAY
 SEDALIA CITY OF
 200 S OSAGE AVE
 SEDALIA, MO 65301
 Phone: 660 827 3000

Prepared by:
 Mike Talleur
 PREMIER TRUCK GROUP OF
 COLUMBIA
 1660 JADE ROAD
 COLUMBIA, MO 65201
 Phone: 1-573-886-0429

| Description | Weight Front | Weight Rear |
|--|--------------|-------------|
| C-BAR MIRROR SYSTEM WITH DUAL HEATED MIRRORS WITH INTEGRAL HEATED CONVEX, DUAL REMOTE, STAINLESS STEEL BACK COVER, AND BLACK C-BAR | | |
| 102 INCH EQUIPMENT WIDTH | | |
| LH AND RH CONVEX MIRRORS INTEGRAL WITH PRIMARY MIRRORS | | |
| RH DOWN VIEW MIRROR | | |
| STANDARD SIDE/REAR REFLECTORS | | |
| UNPOLISHED ALUMINUM WST AFTERTREATMENT SYSTEM COVER | | |
| NO SLEEPER VENT | -10 | |
| STAINLESS STEEL EXTERIOR SUN VISOR WITH INTEGRAL MARKER LIGHTS | 16 | |
| SINGLE SOLAR TINTED REAR WINDOW, (1) 31 INCH X 20 INCH | -10 | |
| 1-PIECE ROPED-IN SOLAR GREEN GLASS WINDSHIELD | | |
| 8 LITER (2 GAL) WINDSHIELD WASHER RESERVOIR, CAB MOUNTED, WITH FLUID LEVEL INDICATOR | | |
| Cab Interior | | |
| X-SERIES BASE INTERIOR TRIM LEVEL PACKAGE | | |
| CHARCOAL BLACK VINYL BASE LEVEL INTERIOR | | |
| CARBON WITH BASE BLACK ACCENT | | |
| BLACK MATS | | |
| (2) DASH MOUNTED POWER OUTLETS AND COIN TRAY | | |
| FORWARD ROOF MOUNTED CONSOLE | | |
| LH AND RH DOOR STORAGE POCKETS INTEGRATED INTO MOLDED DOOR PANELS | | |
| (2) COAT HOOKS ON BACKWALL OF CAB | | |
| NO UPPER BUNK | -50 | -50 |
| DIGITAL ALARM CLOCK IN DRIVER DISPLAY | | |
| 2-1/2 LB. FIRE EXTINGUISHER SHIPPED LOOSE IN CAB | 5 | |
| STANDARD HEATER PLUMBING WITH BALL SHUTOFF VALVES AT SUPPLY LINES ONLY | | |
| RADIATOR MOUNTED AIR CONDITIONER CONDENSER | | |
| STANDARD INSULATION | | |

Prepared for:
 JUSTIN BRAY
 SEDALIA CITY OF
 200 S OSAGE AVE
 SEDALIA, MO 65301
 Phone: 660 827 3000

Prepared by:
 Mike Talleur
 PREMIER TRUCK GROUP OF
 COLUMBIA
 1660 JADE ROAD
 COLUMBIA, MO 65201
 Phone: 1-573-886-0429

| Description | Weight Front | Weight Rear |
|--|--------------|-------------|
| STANDARD LED CAB LIGHTING | | |
| NO SECURITY DEVICE | | |
| DOOR LOCKS AND IGNITION SWITCH KEYED THE SAME | | |
| KEY QUANTITY OF 4 | | |
| LH AND RH ELECTRIC DOOR LOCKS WITH AUTO UNLOCK FEATURE WHEN DOOR IS SET FROM OPEN TO CLOSED POSITION | | |
| BLACK DOOR HANDLES | | |
| NO MATTRESS | -20 | -15 |
| ELITE 2.0 HIGH BACK AIR SUSPENSION DRIVER SEAT W/2 AIR LUMBAR,ACTIVE BOLSTER,INTEGRATED CUSHION EXTENSION, TILT,ADJUSTABLE SHOCK, MAP POCKET, HEAT & VENTILATION | 30 | |
| BATTERY BOX MID BACK NON SUSPENSION PASSENGER SEAT | | |
| BLACK SUSPENSION COVER FOR AIR DRIVER SEAT | 2 | |
| INBOARD DRIVER SEAT ARMREST, NO PASSENGER SEAT ARMREST | 2 | |
| BLACK MORDURA CLOTH DRIVER SEAT COVER WITH EMBROIDERED LOGO | | |
| BLACK MORDURA CLOTH PASSENGER SEAT COVER WITH NO LOGO | | |
| 3 POINT HIGH VISIBILITY ORANGE ADJUSTABLE D-RING RETRACTOR DRIVER AND FIXED D-RING RETRACTOR PASSENGER SEAT BELTS | | |
| ADJUSTABLE TILT AND TELESCOPING STEERING COLUMN | | |
| 4-SPOKE 18 INCH (450MM) BLACK STEERING WHEEL WITH SWITCHES | | |
| DRIVER AND PASSENGER INTERIOR SUN VISORS | | |

Instruments & Controls

STANDARD FOOT PEDAL SYSTEM
 ELECTRONIC ACCELERATOR CONTROL WITH KICK DOWN FEATURE
 BLACK GAUGE BEZELS
 STANDARD CENTER INSTRUMENT PANEL
 DUAL NEEDLE PRIMARY AND SECONDARY AIR PRESSURE GAUGE
 INTAKE MOUNTED AIR RESTRICTION INDICATOR WITHOUT GRADUATIONS

Prepared for:
 JUSTIN BRAY
 SEDALIA CITY OF
 200 S OSAGE AVE
 SEDALIA, MO 65301
 Phone: 660 827 3000

Prepared by:
 Mike Talleur
 PREMIER TRUCK GROUP OF
 COLUMBIA
 1660 JADE ROAD
 COLUMBIA, MO 65201
 Phone: 1-573-886-0429

| Description | Weight Front | Weight Rear |
|--|-----------------|----------------|
| ELECTRONIC CRUISE CONTROL WITH CONTROLS ON STEERING WHEEL SPOKES | | |
| KEY OPERATED IGNITION SWITCH AND INTEGRAL START POSITION; 4 POSITION OFF/RUN/START/ACCESSORY | | |
| PREMIUM INSTRUMENT CLUSTER WITH 5.0 INCH TFT COLOR DISPLAY | | |
| DIGITAL PANEL LAMP DIMMER SWITCH IN DRIVER DISPLAY | | |
| HEAVY DUTY ONBOARD DIAGNOSTICS INTERFACE CONNECTOR WITH DUST CAP LOCATED BELOW LH DASH | | |
| 2 INCH ELECTRIC FUEL GAUGE | | |
| FUEL FILTER RESTRICTION INDICATOR | | |
| ENGINE REMOTE INTERFACE WITH ONE OR MORE SET SPEEDS | | |
| NO PREWIRED HIGH POWER CIRCUIT | | |
| DIGITAL DUAL REAR AXLE TEMPERATURE IN DRIVER DISPLAY WITH SENSOR SHIELDS | | |
| ELECTRICAL ENGINE COOLANT TEMPERATURE GAUGE | | |
| ENGINE OIL TEMPERATURE GAUGE | | |
| ELECTRIC ENGINE OIL PRESSURE GAUGE | | |
| 2 INCH TRANSMISSION OIL TEMPERATURE GAUGE | | |
| ELECTRONIC OUTSIDE TEMPERATURE SENSOR DISPLAY IN DRIVER MESSAGE CENTER | | |
| ENGINE AND TRIP HOUR METERS INTEGRAL WITHIN DRIVER DISPLAY | | |
| PTO CONTROLS FOR ENHANCED VEHICLE ELECTRIC/ELECTRONIC ARCHITECTURE | | |
| NO OBSTACLE DETECTION SYSTEM | | |
| NO DR ASSIST SYSTEM | | |
| ELECTRONIC STABILITY CONTROL | | |
| NO LANE DEPARTURE WARNING SYSTEM | | |
| 1 QUICKFIT PROGRAMABLE MODULE (QPM/XMC) | 10 | |
| TMC RP1226 ACCESSORY CONNECTOR LOCATED BEHIND PASSENGER SIDE REMOVEABLE DASH PANEL | | |

Prepared for:
 JUSTIN BRAY
 SEDALIA CITY OF
 200 S OSAGE AVE
 SEDALIA, MO 65301
 Phone: 660 827 3000

Prepared by:
 Mike Talleur
 PREMIER TRUCK GROUP OF
 COLUMBIA
 1660 JADE ROAD
 COLUMBIA, MO 65201
 Phone: 1-573-886-0429

| Description | Weight Front | Weight Rear |
|---|-----------------|----------------|
| 7" B-PANEL INTERACTIVE TOUCHSCREEN DISPLAY W/ USB-C, APPLE CARPLAY, ANDROID AUTO, BLUETOOTH/AM/FM/SXM/WB, MICROPHONE DASH MOUNTED RADIO STANDARD SPEAKER SYSTEM AM/FM ANTENNA MOUNTED ON RH SIDE MIRROR POWER AND GROUND WIRING PROVISION OVERHEAD ROOF/OVERHEAD CONSOLE CB RADIO PROVISION NO SPEAKER/LEAD FOR 2-WAY RADIO SINGLE FIBERGLASS LH MIRROR MOUNTED CB ANTENNA WITH BRACKET AND LEAD INTEROPERABLE SDAR ANTENNA ELECTRONIC MPH SPEEDOMETER WITH SECONDARY KPH SCALE, WITHOUT ODOMETER ELECTRONIC 2500 RPM TACHOMETER DETROIT CONNECT PLATFORM HARDWARE 5 YEARS DETROIT CONNECT BASE PACKAGE(FEATURES VARY BY MODEL) DETROIT CONNECT PLATFORM IGNITION SWITCH CONTROLLED ENGINE STOP PRE-TRIP INSPECTION FEATURE FOR EXTERIOR LAMPS ONLY REAR SPRING LOADED HAND CONTROL BRAKE VALVE DIGITAL TURBO AIR PRESSURE IN DRIVER DISPLAY DIGITAL VOLTAGE DISPLAY INTEGRAL WITH DRIVER DISPLAY ROTARY HEADLAMP SWITCH, MARKER LIGHTS/HEADLIGHTS SWITCH WITH PULL OUT FOR OPTIONAL FOG/ROAD LAMPS ONE VALVE PARKING BRAKE SYSTEM WITH DASH VALVE CONTROL AUTONEUTRAL AND WARNING INDICATOR SELF CANCELING TURN SIGNAL SWITCH WITH DIMMER, HEADLAMP FLASH, WASH/WIPE/INTERMITTENT QUICKFIT POWERTRAIN INTERFACE CONNECTOR UNDER CAB WITH CAPS | 2 | |

Prepared for:
 JUSTIN BRAY
 SEDALIA CITY OF
 200 S OSAGE AVE
 SEDALIA, MO 65301
 Phone: 660 827 3000

Prepared by:
 Mike Talleur
 PREMIER TRUCK GROUP OF
 COLUMBIA
 1660 JADE ROAD
 COLUMBIA, MO 65201
 Phone: 1-573-886-0429

| | Description | Weight Front | Weight Rear |
|-----------------------------------|--|--------------|-------------|
| Design | QUICKFIT PROGRAMMABLE INTERFACE CONNECTOR(S) UNDER CAB WITH CAP | | |
| Color | PAINT: ONE SOLID COLOR | | |
| Certification / Compliance | CAB COLOR A: L0214EY RED ELITE EY BLACK, HIGH SOLIDS POLYURETHANE CHASSIS PAINT | | |
| | U.S. FMVSS CERTIFICATION, EXCEPT SALES CABS AND GLIDER KITS | | |

TOTAL VEHICLE SUMMARY

| Weight Summary | | | |
|---------------------------------|------------------|-----------------|------------------|
| | Weight Front | Weight Rear | Total Weight |
| Factory Weight ⁺ | 10151 lbs | 8858 lbs | 19009 lbs |
| Total Weight⁺ | 10151 lbs | 8858 lbs | 19009 lbs |

(+) Weights shown are estimates only.
 If weight is critical, contact Customer Application Engineering.

(***) All cost increases for major components (Engines, Transmissions, Axles, Front and Rear Tires) and government mandated requirements, tariffs, and raw material surcharges will be passed through and added to factory invoices.

Prepared for:
 JUSTIN BRAY
 SEDALIA CITY OF
 200 S OSAGE AVE
 SEDALIA, MO 65301
 Phone: 660 827 3000

Prepared by:
 Mike Tailleur
 PREMIER TRUCK GROUP OF
 COLUMBIA
 1660 JADE ROAD
 COLUMBIA, MO 65201
 Phone: 1-573-886-0429

DIMENSIONS

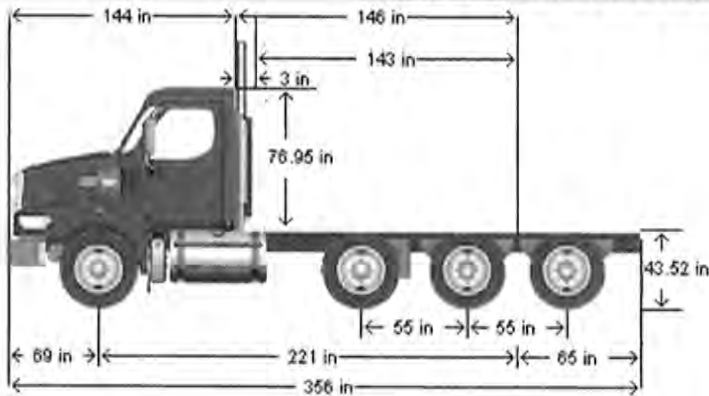

VEHICLE SPECIFICATIONS SUMMARY - DIMENSIONS

| | |
|--------------------------------------|---|
| Model..... | 49X |
| Wheelbase (545) | 5625MM (221 INCH) WHEELBASE |
| Rear Frame Overhang (552) | 1650MM (65 INCH) REAR FRAME OVERHANG |
| Fifth Wheel (578) | NO FIFTH WHEEL |
| Mounting Location (577) | NO FIFTH WHEEL LOCATION |
| Maximum Forward Position (in) | 0 |
| Maximum Rearward Position (in) | 0 |
| Amount of Slide Travel (in) | 0 |
| Slide Increment (in) | 0 |
| Desired Slide Position (in) | 0.0 |
| Cab Size (829)..... | 121 INCH BBC ALUMINUM CONVENTIONAL CAB |
| Sleeper (682)..... | NO SLEEPER BOX/SLEEPER CAB |
| Exhaust System (016)..... | RH OUTBOARD UNDER STEP MOUNTED HORIZONTAL AFTERTREATMENT SYSTEM ASSEMBLY WITH RH B-PILLAR MOUNTED VERTICAL TAILPIPE |

TABLE SUMMARY - DIMENSIONS

Prepared for:
 JUSTIN BRAY
 SEDALIA CITY OF
 200 S OSAGE AVE
 SEDALIA, MO 65301
 Phone: 660 827 3000

Prepared by:
 Mike Talleur
 PREMIER TRUCK GROUP OF
 COLUMBIA
 1660 JADE ROAD
 COLUMBIA, MO 65201
 Phone: 1-573-886-0429

| Dimensions | Inches |
|--|--------|
| Bumper to Back of Cab (BBC) | 144.1 |
| Bumper to Centerline of Front Axle (BA) | 69.1 |
| Front Axle to Back of Cab (AC) | 75.0 |
| Min. Cab to Body Clearance (CB) | 3.0 |
| Back of Cab to Centerline of Rear Axle(s) (CA) | 146.5 |
| Effective Back of Cab to Centerline of Rear Axle(s) (Effective CA) | 143.5 |
| Back of Cab Protrusions (Exhaust/Intake) (CP) | 2.0 |
| Back of Cab Protrusions (Side Extenders/Trim Tab) (CP) | 0.0 |
| Back of Cab Protrusions (CNG Tank) | 0.0 |
| Back of Cab Clearance (CL) | 3.0 |
| Back of Cab to End of Frame | 211.5 |
| Cab Height (CH) | 76.9 |
| Wheelbase (WB) | 221.5 |
| Frame Overhang (OH) | 65.0 |
| Overall Frame Length | 355.4 |
| Overall Length (OAL) | 355.5 |
| Rear Axle Spacing | 55.0 |
| Pusher/Tag Axle Spacing | 55.0 |
| Unladen Frame Height at Centerline of Rear Axle | 43.5 |

Performance calculations are estimates only. If performance calculations are critical, please contact Customer Application Engineering.

**CITY COUNCIL
OF THE CITY OF SEDALIA, MISSOURI**

RESOLUTION NO. _____

**A RESOLUTION OF THE CITY COUNCIL OF THE CITY OF SEDALIA, MISSOURI,
STATING FACTS AND REASONS FOR THE NECESSITY TO AMEND AND INCREASE
THE CITY'S ANNUAL BUDGET FOR FISCAL YEAR 2025.**

WHEREAS, Section 67.010 of the Revised Statutes of Missouri requires each political subdivision of the State of Missouri ("State") to prepare an annual budget and establishes the requirements for that budget; and

WHEREAS, the City of Sedalia, Missouri ("City"), is a city of the third classification created pursuant to Chapter 77, RSMo, and is a political subdivision of the State of Missouri; and

WHEREAS, the City Council of the City adopted and approved the City's annual budget for Fiscal Year 2025 in accordance with the requirements of Section 67.010, RSMo, by Ordinance No. 11990 on March 18, 2024, and

WHEREAS, Sections 67.030 and 67.040 authorize and provide a procedure for the City Council to amend the City's annual budget to increase expenditures in any fund; and

WHEREAS, expenses for City's operations for Fiscal Year 2025 have been higher than budgeted, but do not exceed revenues plus the City's unencumbered balance brought forward from previous years; and

WHEREAS, the City Council of the City desire to state the facts and reasons necessitating an amendment to increase certain expenditures in the Fiscal Year 2025 annual budget.

NOW THEREFORE, BE IT RESOLVED BY THE CITY COUNCIL OF THE CITY OF SEDALIA, MISSOURI, AS FOLLOWS:

Section 1. Expenditures from the City's Sanitation Fund must be increased by a total of \$299,000 above the amount authorized in the adopted annual budget for Fiscal Year 2025. An amendment to increase said budget is necessary for the following facts and reasons:

- A. Purchase Side Load Refuse Truck, where cost includes credit for trade-ins.

Section 2. This Resolution shall take effect immediately upon its execution by the Mayor or otherwise as provided by law.

PASSED by the City Council of the City of Sedalia, Missouri, on August 5, 2024

Presiding Officer of the Council

ATTEST: _____
Jason S. Myers, City Clerk

BILL NO. _____

ORDINANCE NO. _____

AN ORDINANCE AMENDING THE BUDGET FOR THE FISCAL YEAR 2024-2025 REGARDING SANITATION SIDE LOAD REFUSE TRUCK PURCHASE.

NOW THEREFORE, BE IT ORDAINED BY THE COUNCIL OF THE CITY OF SEDALIA, MISSOURI as follows:

Section 1. The 2024-2025 fiscal year budget beginning April 1, 2024 and ending March 31, 2025 is hereby amended to modify certain budgeted line items as they appear on the attached schedule and made a part hereof as Exhibit A as if fully set out herein.

Section 2. This ordinance shall be in full force and effect from and after its passage and approval.

Read two times by title, copies of the proposed ordinance having been made available for public inspection prior to the time the bill is under consideration by the Council and passed by the Council of the City of Sedalia, Missouri this 5th day of August 2024.

Presiding Officer of the Council

Approved by the Mayor of said City this 5th day of August 2024.

Andrew L. Dawson, Mayor

ATTEST:

Jason S. Myers
City Clerk

Exhibit A
City of Sedalia
FY25 Budget Amendment 8/5/2024 Sanitation Side Load Refuse Truck

| Account / Description | Current Budget | Change | Amended Budget | Comments |
|-------------------------------------|-------------------|---------------------|-------------------|---|
| Expenditures / Uses of Funds | | | | |
| 65-51-351-85 Refuse Truck | - | 299,000.00 | 299,000.00 | Side Load Refuse Truck \$399,500 Less Trade-in Values (\$100,500) |
| Total Expenditure Change | | <u>299,000.00</u> | | |
| | | <u>(299,000.00)</u> | | Net Increase (Decrease) in Projected Fund Balance |

BILL NO. _____

ORDINANCE NO. _____

AN ORDINANCE APPROVING AND ACCEPTING A QUOTE FOR THE PURCHASE OF A SIDE LOAD REFUSE TRUCK.

WHEREAS, The City of Sedalia, Missouri, has received a quote from Elliott Equipment Co. for the purchase of a 2025 Peterbuilt 520, Paccar PX-9 380 Diesel side load truck for Sanitation; and

WHEREAS, under the terms of the Quote, the City of Sedalia shall pay the sum and amount of Two Hundred Ninety-nine Thousand Dollars (\$299,000.00) to Elliott Equipment Co. for said truck as more fully described in the quote attached to this Ordinance and incorporated by reference herein.

NOW THEREFORE, BE IT ORDAINED BY THE COUNCIL OF THE CITY OF SEDALIA, MISSOURI, as follows:

Section 1. The Council of the City of Sedalia, Missouri, hereby approves and accepts the quote from Elliott Equipment Co. in substantively the same form and content as the quote has been proposed.

Section 2. The Mayor or City Administrator are authorized and directed to execute and the City Clerk is hereby authorized and directed to attest and fix the seal of the City of Sedalia, Missouri, on any other documentation, if necessary, in substantively the same form and content as the quote has been proposed.

Section 3. The City Clerk is hereby directed to file in his office a duplicate or copy of the quote and any other subsequent documentation after it has been executed by the parties or their duly authorized representatives.

Section 4. This ordinance shall take effect and be in full force and effect from and after its passage and approval.

Read two times by title, copies of the proposed ordinance having been made available for public inspection prior to the time the bill is under consideration by the Council and passed by the Council of the City of Sedalia, Missouri this 5th day of August, 2024.

Presiding Officer of the Council

Approved by the Mayor of said City this 5th day of August, 2024.

ATTEST:

Andrew L. Dawson, Mayor

Jason S. Myers, City Clerk



Let's Cross Paths

City of Sedalia

200 S. Osage

Sedalia, MO 65301

(660) 827-3000 www.sedalia.com

To: Kelvin Shaw, City Administrator

From: Justin Bray, PW Operations Director

Date: July 23, 2024

Subject: **BUDGET AMENDMENT SANITATION – PURCHASE OF 2025 PETERBILT 31 YD
AUTOMATED SIDE LOADER GARBAGE TRUCK**

The Public Works Sanitation Division is requesting an increase of \$299,000.00 in Account No. 65-51-351-00 to purchase a 2025 Peterbilt 520 New Way Sidewinder 31 YD Automated Side Loader.

In the past several months the older Automated Side Loaders continue with their history of mechanical issues. The major issue with these trucks are that they are undersized for the job and the arm is not designed for picking up such large loads.

The truck the division is requesting to purchase has several significant advantages; 1) It is a tandem axel, which allows the truck to carry the heavy loads, 2) the arm has less moving parts, and is able to reach out vertically further, can handle up to 1000lbs, 3) and is able to hold 31 YD's of trash.

The division is requesting to trade in all three of the 2019 Mack-McNeilus Trucks for a total of - \$100,500.00. The total cost of the 2025 Peterbilt 520 New Way Sidewinder 31 YD Automated Side Loader is \$399,500.00. After the trade in allowance of \$100,500.00 the total cost for the 2025 Peterbilt will be \$299,000.00.

Please let me know if you need additional information or have any questions.

RECOMMENDATION: It is Public Works Sanitation Division recommendation that City Council approve the requested budget increase of \$299,000.00. For the purchase of a 2025 Peterbilt 520 New Way Sidewinder 31 YD Automated Side Loader.



3100 West 76th Street
Davenport, IA 52806
Ph: 563-391-4840

Elliott Sanitation Equip. Co.
1245 Dawes Avenue
Lincoln, NE 68521
Ph: 402-474-4840

4000 SE Beisser Drive
Grimes, IA 50111
Ph: 515-986-4840
Fx: 515-986-9530

14219 Norby Road
Grandview, MO 64030
Ph: 816-761-4840

4400 E 60th Ave
Commerce City, CO 80022
Ph: 303-853-4840

Quote

| | |
|------------------------|---------|
| Date | Quote # |
| 7/22/2024 | 21385 |
| Proposed Shipping Date | |
| 60-90 Days | |
| Terms | |
| Net 30 | |
| Rep | |
| KMH | |

City of Sedalia
200 S Osage
Sedalia, MO 65301

Here is our quotation on the goods named, subject to the conditions noted:

CONDITIONS: The prices and terms on this quotation are not subject to verbal changes or other agreements unless approved in writing by the Home Office of the Seller. Prices are based on costs and conditions existing on date of quotation and are subject to change by the Seller before final acceptance. All quotations and agreements are contingent upon strikes, accidents, fires, availability of materials and all other causes beyond our control. Typographical and stenographic errors subject to correction. Purchaser agrees to accept either overage or shortage not in excess of ten percent to be charged for pro-rata. Purchaser assumes liability for patent and copyright infringement when goods are made to Purchaser's specifications. When quotation specifies material to be furnished by the purchaser, ample allowance must be made for reasonable spoilage and material must be of suitable quality to facilitate efficient production. Quoted Prices are good for 60 days.

Conditions not specifically stated herein shall be governed by established trade customs. Terms inconsistent with those stated herein which may appear on Purchaser's formal order will not be binding on the Seller.

TERMS: Equipment is due on receipt. Carts, Containers, Parts & service are Net 30 unless otherwise noted on your account. Balances over 30 days from the date of invoice are subject to finance charges up to 1.5% per month.

| Qty | Item | Description | Price | Total |
|-----|----------|---|------------|------------|
| 1 | 11969E | 2025 Peterbilt 520, Paccar PX-9 380 HP diesel, Allison 4500 RDS automatic transmission, tandem axle, New Way Sidewinder 31 yd automated side loader, frame mounted arm with 12' reach and 1,000 lb lifting capacity, hydraulic hopper cover, triple camera system with 7" monitor, work lights, strobe lights. VIN: 698802 WO: 174468 | 399,500.00 | 399,500.00 |
| | Trade In | Customer Trade In Discount (2019 Mack-McNeilus - Vin: 1M2LR2AC9KM001016) | -33,500.00 | -33,500.00 |
| | Trade In | Customer Trade In Discount (2019 Mack-McNeilus - Vin: 1M2LR2AC9KM001017) | -33,500.00 | -33,500.00 |
| | Trade In | Customer Trade In Discount (2019 Mack-McNeilus - Vin: 1M2LR2AC2KM001018) | -33,500.00 | -33,500.00 |

Total \$299,000.00

TO CONFIRM ORDER, SIGN AND RETURN

X _____

BILL NO. _____

ORDINANCE NO. _____

AN ORDINANCE AUTHORIZING AN ANNEXATION AND UTILITY SERVICES AGREEMENT FOR CONNECTION OF PROPERTY LOCATED AT 1420 TIMBER RIDGE DRIVE TO THE CITY OF SEDALIA'S WATER DISTRIBUTION SYSTEM.

WHEREAS, The City of Sedalia, Missouri, has received an annexation and utility services agreement from Zakhariy Izoitza; and

WHEREAS, under the agreement, the City of Sedalia, Missouri agrees to allow Zakhariy Izoitza to connect property at 1420 Timber Ridge Drive that is located outside of the city limits of Sedalia to the City of Sedalia's water distribution system as more fully described in the proposed agreement attached and incorporated by reference as though the proposed agreement were set forth herein.

NOW THEREFORE, BE IT ORDAINED BY THE COUNCIL OF THE CITY OF SEDALIA, MISSOURI, as follows:

Section 1. The Council of the City of Sedalia, Missouri, hereby approves and accepts the agreement by and between the City of Sedalia, Missouri and Zakhariy Izoitza in substantively the same form and content as the agreement has been proposed.

Section 2. The Mayor or City Administrator are authorized and directed to execute and the City Clerk is hereby authorized and directed to attest and fix the seal of the City of Sedalia, Missouri, on the document in substantively the same form and content as it has been proposed.

Section 3. The City Clerk is hereby directed to file in his office a duplicate or copy of the document after it has been executed by the parties or their duly authorized representatives and after said agreement has been recorded with the Pettis County Recorder of Deed's office.

Section 4. This ordinance shall take effect and be in full force and effect from and after its passage and approval.

Read two times by title, copies of the proposed ordinance having been made available for public inspection prior to the time the bill is under consideration by the Council and passed by the Council of the City of Sedalia, Missouri this 5th day of August 2024.

Presiding Officer of the Council

Approved by the Mayor of said City this 5th day of August 2024.

Andrew L. Dawson, Mayor

ATTEST:

Jason S. Myers
City Clerk

ANNEXATION AND UTILITY SERVICES AGREEMENT

This Agreement (hereinafter "Agreement") entered into this 25 day of July, 2024, between the City of Sedalia, Missouri, (hereinafter "City") and Zakhariy Izoitza (hereinafter "Owner").

RECITALS:

1. Whereas, Owner represents that they are the owner of the following real estate (hereinafter referred as "Owner real estate") located in Pettis County, Missouri:

See attached "Exhibit A" as legal description of property and "Exhibit B" for location of property.

2. Whereas, Owner desires to connect Owner's property to the City's water system for purposes of developing Owner's property; and

3. Whereas, City desires to permit Owner to connect to the City's water system for purposes of developing Owner's property; and

4. Whereas, City desires the right to annex Owner's property if Owner's property becomes contiguous to City's corporate city limits; and

NOW, THEREFORE, for and in consideration of the above-recitals as well as the terms and conditions hereafter, the parties hereby agree as follows:

1. Owner, in exchange for the City's agreement to allow Owner to connect its property to the City's water system, the Owner, on behalf of themselves, its successors, heirs and assigns, hereby conveys unto the City the irrevocable and perpetual right to file on its behalf a Petition of Annexation at any time after annexation becomes possible.

2. City shall allow Owner to connect a water line serving Owner's property to the City's water system, and Owner shall make connection at its expense. Prior to approving the physical connection, Owner shall obtain all necessary easements, if needed, from any other landowner and provide recorded copies to the City, obtain permits for the connection and pay all fees required to connect to the City's water system. City shall provide and install water meter and box for connection of Owner's water service line. Owner shall be responsible for connecting the Owner's water service line from the house to the meter. Owner shall become a utility customer of the City and shall pay all fees and charges established by the City for water service.

3. The Owner shall ensure the water service line serving Owner's property is constructed in compliance with City regulations and standards. Construction of the water service line shall be

inspected by the City as though the property were within the City limits and shall be subject to City approval. Owner agrees to bring the new water service line to the City's meter and make connection. Owner shall not be charged for water service until the activation of service with the City of Sedalia.

4. Owner agrees to the "out of city limits" fee/cost schedule for services until such time as the Owner's property is annexed into the City of Sedalia.

5. Water service lines serving property other than the Owner's property shall not be connected to the line serving the Owner's property without the City's written consent.

6. To the extent allowed by law, the City may annex Owner's property into the City, without further action of the Owner, after Owner's property becomes contiguous to the corporate limits of the City.

7. Owner irrevocably appoints the City Administrator of Sedalia, Missouri, as its attorney-in-fact for the sole purpose of presenting a verified petition requesting annexation of Owner's property to the City Council of Sedalia, Missouri. IF AND WHEN the property becomes contiguous and compact to the city limits of the City of Sedalia, Missouri. The City Administrator may exercise this power of attorney at any time after Owner's property becomes contiguous to the corporate limits of the City. Owner on its behalf, and on behalf of its heirs, successors and assigns does hereby waive any notice of the filing of the petition, does hereby consent to the granting of the petition, and does hereby waive any objections, statutory or otherwise, to the annexation of the property into the City of Sedalia. The owner hereby authorizes the City to take whatever action necessary to complete the annexation of this property. Owner's consent to such future annexation of the Property is irrevocable.

8. The parties hereto agree that this Agreement shall be recorded, in the real estate records of the Office of Recorder of Deeds of Pettis County, Missouri, and that the obligations and conditions of this Agreement shall run with the Property and shall be binding upon all future owner and users of the Property. Owner, on its own behalf and on behalf of all such future owner of the Property hereby agrees that each purchaser, assignee or transferee of an interest in the Property, or any portion thereof, will be obligated and bound by the terms of this Agreement. Owner, on its own behalf and on behalf of all future owner of the Property, acknowledges that they and /or future owner of the Property shall be responsible for payment of all properly billed fees for water service as established by the City of Sedalia. Owner's liability contained in this paragraph 8 shall terminate when Owner has transferred its ownership interest in Owner's property to a successor owner, at which time, the successor owner shall be responsible for payment of all properly billed fees for water service as established by the City of Sedalia.

9. Alternatively, if requested by the City Administrator, Owner, its successors, assigns and heirs shall, within such time as specified by the City Administrator, submit a verified petition requesting annexation of the Owner's property to the City Clerk for presentation to the City Council of Sedalia, Missouri. The City Administrator may request Owner to present an annexation petition at any time after Owner's property becomes contiguous to the corporate limits of the City. The provisions of this paragraph shall be enforceable by specific performance.

10. Owner shall give a copy of this Agreement to the person or persons who buy the Owner's property.

11. If Owner fails to comply with any of the provisions of this Agreement, or repudiate the

terms of this Agreement, City may terminate water service to Owner's property and disconnect the utility lines serving Owner' property from the City's water system. City shall give Owner six months prior written notice of its intent to terminate service.

12. This Agreement is not intended to confer any rights or remedies on any person other than the parties.

13. The benefits and burdens of this Agreement are intended to attach to and run with the land and shall be binding on and inure to the benefit of the parties and its respective legal representatives, successors, heirs and assigns. All persons claiming under the parties shall conform to and observe the provisions of this Agreement.

14. This Agreement shall be recorded in the office of the Pettis County Recorder of Deeds at the City's expense.

IN WITNESS WHEREOF, the parties have executed this Agreement on the day and year first above written.

CITY OF SEDALIA, MISSOURI

By: _____

Andrew Dawson, Mayor

ATTEST:

Jason Myers, City Clerk

OWNER:

By:  _____
Zakhariy Izoitza

Exhibit A

See Attached plat recorded as Document _____ in the Pettis County Recorder of Deeds.

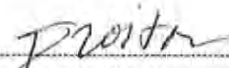

DocId:8156732

Tx:4136293

2023-2705

RECORDED ON
06/22/2023 11:09 AM
PAGES: 2

BARBARA CLEVENGER
RECORDER OF DEEDS
PETTIS COUNTY, MO

QUIT CLAIM DEED

THIS INDENTURE, made on the 22 day of June, 2023, by and between Irina Kislyy, a married person, and her spouse, Daniel Kislyy, of Pettis County, Missouri (hereinafter referred as "Grantor"), and Zakhariy Izoitza, a married person of Pettis County, Missouri (hereinafter referred as "Grantee").

Grantee's Address: 26359 Prairie Road, Sedalia, MO 65301

WITNESSETH, that Grantor, in consideration of the sum of one dollar (\$1.00) and other good and valuable consideration from Grantee, the receipt of which is hereby acknowledged, does by these presents remise, release, and forever Quit-Claim unto Grantee the following described lots, tracts or parcels of land situated in the County of Pettis and State of Missouri, to-wit:

LOT ONE (1), HUNTER'S RIDGE SUBDIVISION IN PETTIS COUNTY, MISSOURI
"SUBJECT TO EASEMENTS APPARENT OR OF RECORD AND RESTRICTIONS, IF ANY."

TO HAVE AND TO HOLD the same, with all the rights immunities, privileges and appurtenances thereto belonging unto Grantee, Grantee's heirs, successors and assigns forever; so that neither Grantor nor Grantor's heirs, successors or assigns, nor any other person or persons for them or in their name or behalf, shall or will hereafter claim or demand any right or title to the aforesaid premises or any part thereof, but they and every one of them shall, by these presents, be excluded and forever barred.

IN WITNESS WHEREOF, Grantor executes this deed on the date and year below.



Irina Kislyy

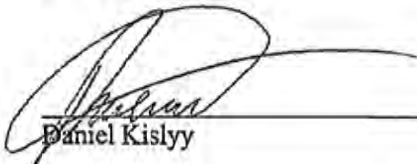

Daniel Kislyy

PETTIS COUNTY, MO RECORDER FOR INFORMATIONAL PURPOSES ONLY.

STATE OF MISSOURI)
) ss.
COUNTY OF PETTIS)

On this 27th day of June, 2023, before me personally appeared Irina Kislyy, to me known to be the person described in and who executed the foregoing instrument and acknowledged that she executed the same as her free act and deed.

IN TESTIMONY WHEREOF, I have hereunto set my hand and affixed my official seal at my office on the day and year above written.

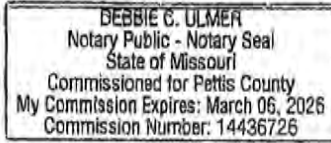

Debbie C. Ulmer
Notary Public

STATE OF MISSOURI)
) ss.
COUNTY OF PETTIS)

On this 27th day of June, 2023, before me personally appeared Daniel Kislyy, to me known to be the person described in and who executed the foregoing instrument and acknowledged that he executed the same as his free act and deed.

IN TESTIMONY WHEREOF, I have hereunto set my hand and affixed my official seal at my office on the day and year above written.

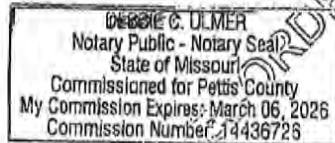

Debbie C. Ulmer
Notary Public

PETTIS COUNTY, MO. RECORDER FOR INFORMATIONAL PURPOSES ONLY.

Exhibit B



Overview



Legend

-  Political Townships
-  Corporate Limits
-  Parcels
-  Roads

| | | | | | |
|-----------------------|--|--------------|-------------|---------------|------------------------|
| Parcel ID | 141002404001000 | Alternate ID | n/a | Owner Address | IZOITZA, ZAKHARIY |
| Sec/Twp/Rng | 2/45/22 | Class | Residential | | 26359 PRAIRIE RD |
| Property Address | 1420 EAST TIMBER RIDGE DR SEDALIA | Acreage | 0.369 | | SEDALIA, MO 65301-9118 |
| District | R004 | | | | |
| Brief Tax Description | LOT 1 HUNTER'S RIDGE 1ST 2-45-22 <i>(Note: Not to be used on legal documents)</i> | | | | |

Disclaimer. The information provided on this site is for convenience only and is compiled from recorded deeds, plats, tax maps, surveys, and other public records and data. In the preparation of this site, extensive efforts have been made to offer the most current, correct, and clearly expressed information possible. However, inadvertent errors can occur, and information placed on this site is not intended to replace any official source. The applicable county sources should be consulted for verification of the information provided on these pages. Users are advised that their use of any of this information is at their own risk.

Date created: 6/17/2024
Last Data Uploaded: 6/17/2024 4:32:10 AM

Developed by  Schneider
GEOSPATIAL

BILL NO. _____

ORDINANCE NO. _____

AN ORDINANCE AUTHORIZING AN ANNEXATION AND UTILITY SERVICES AGREEMENT FOR CONNECTION OF PROPERTY LOCATED AT 2685 JAMES LANE TO THE CITY OF SEDALIA'S WATER DISTRIBUTION SYSTEM.

WHEREAS, The City of Sedalia, Missouri, has received an annexation and utility services agreement from Herman S. and Debra K. Collier; and

WHEREAS, under the agreement, the City of Sedalia, Missouri agrees to allow Herman S. and Debra K. Collier to connect property at 2685 James Lane that is located outside of the city limits of Sedalia to the City of Sedalia's water distribution system as more fully described in the proposed agreement attached and incorporated by reference as though the proposed agreement were set forth herein.

NOW THEREFORE, BE IT ORDAINED BY THE COUNCIL OF THE CITY OF SEDALIA, MISSOURI, as follows:

Section 1. The Council of the City of Sedalia, Missouri, hereby approves and accepts the agreement by and between the City of Sedalia, Missouri and Herman S. and Debra K. Collier in substantively the same form and content as the agreement has been proposed.

Section 2. The Mayor or City Administrator are authorized and directed to execute and the City Clerk is hereby authorized and directed to attest and fix the seal of the City of Sedalia, Missouri, on the document in substantively the same form and content as it has been proposed.

Section 3. The City Clerk is hereby directed to file in his office a duplicate or copy of the document after it has been executed by the parties or their duly authorized representatives and after said agreement has been recorded with the Pettis County Recorder of Deed's office.

Section 4. This ordinance shall take effect and be in full force and effect from and after its passage and approval.

Read two times by title, copies of the proposed ordinance having been made available for public inspection prior to the time the bill is under consideration by the Council and passed by the Council of the City of Sedalia, Missouri this 5th day of August 2024.

Presiding Officer of the Council

Approved by the Mayor of said City this 5th day of August 2024.

Andrew L. Dawson, Mayor

ATTEST:

Jason S. Myers
City Clerk



Let's Cross Paths

City of Sedalia

200 S. Osage

Sedalia, MO 65301

(660) 827-3000 www.sedalia.com

To: Kelvin Shaw, City Administrator
Through: William Bracken, Utilities Director
From: Elizabeth Nations, Executive Administrative Assistant
Date: July 29, 2024
Subject: Annexation Agreement for Water Service

Please find attached an annexation agreement between the City of Sedalia and Herman S. and Debra K. Collier for the property now addressed as 2685 James Lane. Herman S. and Debra K. Collier are requesting connection to the City's water distribution system and has agreed to pay the "out of City limits" rates until such time as the property is annexed into the City.

The agreement is written to allow the City to disconnect the water line should Herman S. and Debra K. Collier not complete the annexation process. Herman S. and Debra K. Collier have already signed and have notarized the agreement.

ANNEXATION AND UTILITY SERVICES AGREEMENT

This Agreement (hereinafter "Agreement") entered into this 19th day of _____, 2024, between the City of Sedalia, Missouri, (hereinafter "City") and Herman S. Collier and Debra K. Collier (hereinafter "Owners").

RECITALS:

1. Whereas, Owners represent that they are the owners of the following real estate (hereinafter referred as "Owners real estate") located in Pettis County, Missouri:

See attached "Exhibit A" as legal description of property and "Exhibit B" for location of property.

2. Whereas, Owners desire to connect Owners' property to the City's water system for purposes of developing Owner's property; and

3. Whereas, City desires to permit Owners to connect to the City's water system for purposes of developing Owner's property; and

4. Whereas, City desires the right to annex Owners' property if Owners' property becomes contiguous to City's corporate city limits; and

NOW, THEREFORE, for and in consideration of the above-recitals as well as the terms and conditions hereafter, the parties hereby agree as follows:

1. Owners, in exchange for the City's agreement to allow Owners to connect their property to the City's water system, the Owners, on behalf of themselves, their successors, heirs and assigns, hereby conveys unto the City the irrevocable and perpetual right to file on their behalf a Petition of Annexation at any time after annexation becomes possible.

2. City shall allow Owners to connect a water line serving Owners' property to the City's water system, and Owners shall make connection at their expense. Prior to approving the physical connection, Owners shall obtain all necessary easements, if needed, from any other landowners and provide recorded copies to the City, obtain permits for the connection and pay all fees required to connect to the City's water system. City shall provide and install water meter and box for connection of Owners' water service line. Owners shall be responsible for connecting the Owners' water service line from the house to the meter. Owners shall become a utility customer of the City and shall pay all fees and charges established by the City for water service.

3. The Owners shall ensure the water service line serving Owners' property is constructed in compliance with City regulations and standards. Construction of the water service line shall be

inspected by the City as though the property were within the City limits and shall be subject to City approval. Owners agree to bring the new water service line to the City's meter and make connection. Owners shall not be charged for water service until the activation of service with the City of Sedalia.

4. Owners agree to the "out of city limits" fee/cost schedule for services until such time as the Owners' property is annexed into the City of Sedalia.

5. Water service lines serving property other than the Owners' property shall not be connected to the line serving the Owners' property without the City's written consent.

6. To the extent allowed by law, the City may annex Owners' property into the City, without further action of the Owners, after Owners' property becomes contiguous to the corporate limits of the City.

7. Owners irrevocably appoint the City Administrator of Sedalia, Missouri, as its attorney-in- fact for the sole purpose of presenting a verified petition requesting annexation of Owners' property to the City Council of Sedalia, Missouri, IF AND WHEN the property becomes contiguous and compact to the city limits of the City of Sedalia, Missouri. The City Administrator may exercise this power of attorney at any time after Owners' property becomes contiguous to the corporate limits of the City. Owners on their behalf, and on behalf of their heirs, successors and assigns do hereby waive any notice of the filing of the petition, do hereby consent to the granting of the petition, and do hereby waive any objections, statutory or otherwise, to the annexation of the property into the City of Sedalia . Owners do hereby authorize the City to take whatever action necessary to complete the annexation of this property. Owners' consent to such future annexation of the Property is irrevocable.

8. The parties hereto agree that this Agreement shall be recorded , in the real estate records of the Office of Recorder of Deeds of Pettis County , Missouri, and that the obligations and conditions of this Agreement shall run with the Property and shall be binding upon all future owners and users of the Property. Owners, on their own behalf and on behalf of all such future owners of the Property hereby agree that each purchaser, assignee or transferee of an interest in the Property, or any portion thereof, will be obligated and bound by, the terms of this Agreement. Owners, on their own behalf and on behalf of all future owners of the Property, acknowledges that they and /or future owners of the Property shall be responsible for payment of all properly billed fees for water service as established by the City of Sedalia. Owners' liability contained in this paragraph 8 shall terminate when Owners have transferred their ownership interest in Owners' property to a successor owner, at which time, the successor owner shall be responsible for payment of all properly billed fees for water service as established by the City of Sedalia.

9. Alternatively, if requested by the City Administrator, Owners, their successors, assigns and heirs shall, within such time as specified by the City Administrator, submit a verified petition requesting annexation of the Owners' property to the City Clerk for presentation to the City Council of Sedalia, Missouri. The City Administrator may request Owners to present an annexation petition at any time after Owners' property becomes contiguous to the corporate limits of the City. The provisions of this paragraph shall be enforceable by specific performance.

10. Owners shall give a copy of this Agreement to the person or persons who buy the Owners' property.

11. If Owners fail to comply with any of the provisions of this Agreement, or repudiate the terms of this Agreement, City may terminate water service to Owners' property and disconnect the utility lines serving Owners' property from the City's water system. City shall give Owners six months prior written notice of its intent to terminate service.

12. This Agreement is not intended to confer any rights or remedies on any person other than the parties.

13. The benefits and burdens of this Agreement are intended to attach to and run with the land and shall be binding on and inure to the benefit of the parties and their respective legal representatives, successors, heirs and assigns. All persons claiming under the parties shall conform to and observe the provisions of this Agreement.

14. This Agreement shall be recorded in the office of the Pettis County Recorder of Deeds at the City's expense.

IN WITNESS WHEREOF, the parties have executed this Agreement on the day and year first above written.

CITY OF SEDALIA, MISSOURI

By: _____

Andrew Dawson, Mayor

ATTEST:

Jason Myers, City Clerk

OWNER: Herman S. Collier

By:  _____
Herman S. Collier, Owner

OWNER: Debra K. Collier

By:  _____
Debra K. Collier, Owner

On the _____ day of July, 2024 before me appeared _____, to me personally known, who, being by me duly sworn, did say that he is the Mayor of the City of Sedalia, Missouri, and that the seal affixed to the foregoing instrument is the corporate seal of the City and that this instrument was signed and sealed on behalf of the City by authority of its City Council and the Mayor acknowledged this instrument to be the free act and deed of the City.

IN TESTIMONY WHEREOF, I have hereunto set by hand and affixed my official seal my office in Sedalia, Pettis County, Missouri, the day and year first above written.

By: _____
Andrew Dawson, Mayor

ACKNOWLEDGMENT BY OWNER, CORPORATION OR ASSOCIATION

STATE OF MISSOURI)
) ss
COUNTY OF PETTIS)

On the day 19th of July, 2024, before me appeared Herman S. Collier and Debra K. Collier, to me personally known, who, being by me duly sworn, did say that he is the Owner of 2685 James Lane, and that said instrument was signed by him and acknowledged the said instrument to be a free act and deed of Herman S. Collier.

IN TESTIMONY WHEREOF, I have hereunto set my hand and affixed my official seal in the County and state aforesaid the day and year first above written.



Janeice D. Dodick
Notary Public

Exhibit A

See Attached plat recorded as Document _____ in the Pettis County Recorder of Deeds.

2021-6525

RECORDED ON
10/29/2021 12:04 PM
PAGES: 2

BARBARA CLEVINGER
RECORDER OF DEEDS
PETTIS COUNTY, MO

MISSOURI WARRANTY DEED

This Deed, Made and entered into this 28th day of October, 2021, by and between

MVRK DEVELOPING, LLC, a MISSOURI Limited Liability Company as "GRANTOR",

and

HERMAN S. COLLIER and DEBRA K. COLLIER, husband and wife, of the State of MISSOURI, and County of PETTIS, as "GRANTEE",

Grantee's mailing address: 2520 JAMES LANE SEDALIA, MISSOURI 65301

WITNESSETH, that the Grantor, in consideration of the sum of Ten Dollars (\$10.00) and other valuable consideration paid by the Grantee, the receipt and sufficiency of which is hereby acknowledged, does hereby GRANT, BARGAIN AND SELL, CONVEY AND CONFIRM unto Grantee, the following described Real Estate, situated in the County of Pettis and State of Missouri, to wit:

(TRACT 1) LOT NUMBER SEVENTY THREE (73) OF WEST COUNTRY CLUB ESTATES PART 4, A SUBDIVISION OF PETTIS COUNTY, MISSOURI.

 **(TRACT 2) LOT NUMBER EIGHTY TWO (82) OF WEST COUNTRY CLUB ESTATES PART 5, A SUBDIVISION OF PETTIS COUNTY, MISSOURI.**

Subject to easements, restrictions, reservations, and covenants of record, if any.

TO HAVE AND TO HOLD the premises aforesaid with all singular, the rights, privileges, appurtenances and immunities thereto belonging or in any wise appertaining unto Grantee and unto Grantee's heirs and assigns forever; the Grantor hereby covenanting that Grantor is lawfully seized of an indefeasible estate in fee of the premises herein conveyed; that Grantor has good right to convey the same; that the said premises are free and clear from any encumbrance done or suffered by Grantor or those under whom Grantor claims, except as stated above and except for all taxes and assessments, general and special, not now due and payable, and that Grantor will warrant and defend the title to the said premises unto Grantee and unto Grantee's heirs and assigns forever, against the lawful claims and demands of all persons whomsoever. If two or more persons constitute the Grantor or Grantee, the words Grantor and Grantee will be construed to read Grantors and Grantees whenever the sense of this Deed requires.

Exhibit B



Overview



Legend

-  Political Townships
-  Corporate Limits
-  Parcels
-  Roads

| | | | | | |
|------------------------------|---|---------------------|-------------|----------------------|-----------------------------|
| Parcel ID | 141001000006687 | Alternate ID | n/a | Owner Address | COLLIER, HERMAN S & DEBRA K |
| Sec/Twp/Rng | 1/45/22 | Class | Residential | | 2520 JAMES LN |
| Property Address | JAMES LN | Acreage | 0.929 | | SEDALIA, MO 65301-6959 |
| | PRAIRIE TWP | | | | |
| District | R004 | | | | |
| Brief Tax Description | LOT 82 WEST COUNTRY CLUB ESTATES PART 5 1-45-22 | | | | |

(Note: Not to be used on legal documents)

Disclaimer. The information provided on this site is for convenience only and is compiled from recorded deeds, plats, tax maps, surveys, and other public records and data. In the preparation of this site, extensive efforts have been made to offer the most current, correct, and clearly expressed information possible. However, inadvertent errors can occur, and information placed on this site is not intended to replace any official source. The applicable county sources should be consulted for verification of the information provided on these pages. Users are advised that their use of any of this information is at their own risk.

Date created: 7/19/2024
 Last Data Uploaded: 7/19/2024 4:43:46 AM

Developed by  **Schneider**
 GEOSPATIAL

**CITY COUNCIL
OF THE CITY OF SEDALIA, MISSOURI**

RESOLUTION NO. _____

**A RESOLUTION OF THE CITY COUNCIL OF THE CITY OF SEDALIA, MISSOURI,
STATING FACTS AND REASONS FOR THE NECESSITY TO AMEND AND INCREASE
THE CITY'S ANNUAL BUDGET FOR FISCAL YEAR 2025.**

WHEREAS, Section 67.010 of the Revised Statutes of Missouri requires each political subdivision of the State of Missouri ("State") to prepare an annual budget and establishes the requirements for that budget; and

WHEREAS, the City of Sedalia, Missouri ("City"), is a city of the third classification created pursuant to Chapter 77, RSMo, and is a political subdivision of the State of Missouri; and

WHEREAS, the City Council of the City adopted and approved the City's annual budget for Fiscal Year 2025 in accordance with the requirements of Section 67.010, RSMo, by Ordinance No. 11990 on March 18, 2024, and

WHEREAS, Sections 67.030 and 67.040 authorize and provide a procedure for the City Council to amend the City's annual budget to increase expenditures in any fund; and

WHEREAS, expenses for City's operations for Fiscal Year 2025 have been higher than budgeted, but do not exceed revenues plus the City's unencumbered balance brought forward from previous years; and

WHEREAS, the City Council of the City desire to state the facts and reasons necessitating an amendment to increase certain expenditures in the Fiscal Year 2025 annual budget.

NOW THEREFORE, BE IT RESOLVED BY THE CITY COUNCIL OF THE CITY OF SEDALIA, MISSOURI, AS FOLLOWS:

Section 1. Expenditures from the City's Transportation Fund must be increased by a total of \$56,781.26 above the amount authorized in the adopted annual budget for Fiscal Year 2025. An amendment to increase said budget is necessary for the following facts and reasons:

- A. Purchase two four-way portable signals.

Section 2. This Resolution shall take effect immediately upon its execution by the Mayor or otherwise as provided by law.

PASSED by the City Council of the City of Sedalia, Missouri, on August 5, 2024

Presiding Officer of the Council

ATTEST: _____
Jason S. Myers, City Clerk

BILL NO. _____

ORDINANCE NO. _____

AN ORDINANCE AMENDING THE BUDGET FOR THE FISCAL YEAR 2024-2025 REGARDING STREET LIGHT SIGNALS PURCHASE.

NOW THEREFORE, BE IT ORDAINED BY THE COUNCIL OF THE CITY OF SEDALIA, MISSOURI as follows:

Section 1. The 2024-2025 fiscal year budget beginning April 1, 2024 and ending March 31, 2025 is hereby amended to modify certain budgeted line items as they appear on the attached schedule and made a part hereof as Exhibit A as if fully set out herein.

Section 2. This ordinance shall be in full force and effect from and after its passage and approval.

Read two times by title, copies of the proposed ordinance having been made available for public inspection prior to the time the bill is under consideration by the Council and passed by the Council of the City of Sedalia, Missouri this 5th day of August 2024.

Presiding Officer of the Council

Approved by the Mayor of said City this 5th day of August 2024.

Andrew L. Dawson, Mayor

ATTEST:

Jason S. Myers
City Clerk

Exhibit A
 City of Sedalia
 FY25 Budget Amendment 8/5/2024 Street Light Purchase

| Account / Description | Current Budget | Change | Amended Budget | Comments |
|-------------------------------------|----------------|--------------------|----------------|--|
| Expenditures / Uses of Funds | | | | |
| 20-64-351-00 Equipment | 551,400.00 | 56,781.26 | 608,181.26 | Street Light Purchase: 2 four-way portable signals |
| Total Expenditure Change | | <u>56,781.26</u> | | |
| | | <u>(56,781.26)</u> | | Net Increase (Decrease) in Projected Fund Balance |

BILL NO. _____

ORDINANCE NO. _____

AN ORDINANCE APPROVING AND ACCEPTING A QUOTE FOR THE PURCHASE OF TWO 4-WAY PORTABLE SIGNALS.

WHEREAS, the City of Sedalia, Missouri has received a proposal from J&A Traffic Products for the purchase of two FRX-PTS 4-Way portable signals; and

WHEREAS, under the proposal, the City of Sedalia, Missouri shall pay J&A Traffic Products the sum and amount of Fifty-six Thousand Seven Hundred Eighty-one Dollars and Twenty-six Cents (\$56,781.26) as more fully described in the quote attached to this Ordinance and incorporated by reference herein.

NOW THEREFORE, BE IT ORDAINED BY THE COUNCIL OF THE CITY OF SEDALIA, MISSOURI as follows:

Section 1. The Council of the City of Sedalia, Missouri hereby approves and accepts the Quote by and between the City of Sedalia, Missouri and J & A Traffic Products as the quote has been proposed.

Section 2. The Mayor or City Administrator are authorized and directed to execute and the City Clerk is hereby authorized and directed to attest and fix the seal of the City of Sedalia, Missouri on the quote in substantively the same form and content as the quote has been proposed.

Section 3. The City Clerk is hereby directed to file in his office a duplicate or copy of the quote after it has been executed by the parties or their duly authorized representatives.

Section 4. This Ordinance shall be in full force and effect from and after its passage and approval.

Read two times by title, copies of the proposed Ordinance having been made available for public inspection prior to the time the bill is under consideration by the Council and passed by the Council of the City of Sedalia, Missouri this 5^h day of August, 2024.

Presiding Officer of the Council

Approved by the Mayor of said City this 5^h day of August, 2024.

Andrew L. Dawson, Mayor

ATTEST:

Jason S. Myers, City Clerk



Let's Cross Paths

City of Sedalia

200 S. Osage

Sedalia, MO 65301

(660) 827-3000 www.sedalia.com

To: Kelvin Shaw, City Administrator
Through: Matthew Wirt, Assistant City Administrator
From: Justin Bray, Public Works Operations Director
Date: July 26, 2024
Subject: 4- Way Portable Signal for Washington St. Bridge

The Public Works Street Division requests approval to purchase a (2) 4 -Way Portable Signals from J&A Traffic Products to provide traffic control for the Washington Street Bridge.

The Missouri Department of Transportation (MODOT) found structural issues with the bridge in February of 2024. This caused City Officials to immediately stop traffic access to the bridge. This month the City worked with HDR, Inc. to establish a plan to reopen the bridge.

The bridge, by a vote from the City Council, was reopened with the direction to establish a single 11- foot lane, which included barriers and signage. The council also voted to purchase traffic signals to be used as traffic control. This will allow traffic to transverse from both the north and the south sides of the bridge.

The division research several options and decided on (2) 4-way portable signals for \$28,390.63 each for a total of \$56,781.26. This option will serve the immediate need for traffic control on the bridge. Once the bridge becomes fully operational, the signals will continue to serve the division's need as a portable traffic control system when conducting the Street Maintenance Program and/or safety related situations.

I recommend purchasing (2) OMJC First Responder – FRX-PTS 4 Way Portable Signal for \$56,781.26, from J&A Traffic Products, 605 SW 40 Hwy, Blue Springs, MO 64014.

Thank you,

Justin Bray,
Operations Director,
Public Works Department

JB/tl



From: Trevor Robbins
Phone: 816-764-4399
Email: trobbins@jatps.com

605 SW. 40 Highway, #119
Blue Springs, MO 64014
Fax: 816-220-3197

QUOTE

To: Justin Bray / Daryn Carver
City of Sedalia

Date: 7/25/2024
Fax: _____

| Quantity | Product Name / Description | Unit | Extended |
|----------|--|--------------|--------------------|
| 2 | OMJC First Responder - FRX-PTS 4 Way Portable Signal | \$28,390.63 | \$56,781.26 |
| | | | |
| | | | |
| | | | |
| | | | |
| | | | |
| | Missouri Buys - IFB605CO23001970 Breakaway Contract | | |
| | | | |
| | | | |
| | | | |
| | | | |
| | | TOTAL | \$56,781.26 |
| | ** Delivered price to Sedalia, MO | | |
| | | | |
| | Thank You! | | |
| | Trevor Robbins | | |

BILL NO. _____

ORDINANCE NO. _____

AN ORDINANCE AUTHORIZING AN AGREEMENT FOR YARD WASTE GRINDING.

WHEREAS, The City of Sedalia, Missouri, has received a proposal from Hansen’s Tree Service; and

WHEREAS, under the proposal, the City of Sedalia, Missouri, shall give the sum and amount of Thirty Nine Thousand Two Hundred Seventy Five (\$39,275.00) to Hansen’s Tree Service for Yard Waste Grinding as described in the proposed agreement attached and incorporated by reference.

NOW THEREFORE, BE IT ORDAINED BY THE COUNCIL OF THE CITY OF SEDALIA, MISSOURI, as follows:

Section 1. The Council of the City of Sedalia, Missouri, hereby approves and accepts the agreement by and between the City of Sedalia, Missouri, and Hansen’s Tree Service in substantively the same form and content as the agreement has been proposed.

Section 2. The Mayor or City Administrator are authorized and directed to execute and the City Clerk is hereby authorized and directed to attest and fix the seal of the City of Sedalia, Missouri, on the document in substantively the same form and content as it has been proposed.

Section 3. The City Clerk is hereby directed to file in his office a duplicate or copy of the document after it has been executed by the parties or their duly authorized representatives.

Section 4. This ordinance shall take effect and be in full force and effect from and after its passage and approval.

Read two times by title, copies of the proposed ordinance having been made available for public inspection prior to the time the bill is under consideration by the Council and passed by the Council of the City of Sedalia, Missouri this 5th day of August 2024.

Presiding Officer of the Council

Approved by the Mayor of said City this 5th day of August 2024.

Andrew L. Dawson, Mayor

ATTEST:

Jason S. Myers, City Clerk



Let's Cross Paths

City of Sedalia

200 S. Osage

Sedalia, MO 65301

(660) 827-3000 www.sedalia.com

To: Kelvin Shaw, City Administrator
Through: Chris Davies, City Engineer
From: Jeremy Stone, Public Works Project Manager
Date: July 23, 2024
Subject: IFB 2025-004 Yard Waste Grinding 2024

The Public Works Department received three (3) bids for the above mentioned project. The bids received were as follows and the bid tabs are attached.

- Hansen's Tree Service of O'Fallon, MO-\$39,275.00 (bid bond included, Addendum 1 was not acknowledged)
- Smithey Environmental Services, LLC. Of Tulsa, OK- \$2.50/Cubic Yard (no bid bond included, bid form was changed from per site to cubic yard without a total price listed, Addendum 1 acknowledged)
- Hercules Weld and Fab LLC of Windsor, MO-\$225,000.00 (Bid bond included, Addendum 1 acknowledged)

The Public Works Department recommends the low bid from Hansen's Tree Service for \$39,275.00 be accepted, clarification was made that Hansen's Tree Service did acknowledge Addendum 1. This falls under the City's budget of \$54,000 and would allow for another small grinding project later in the fiscal year, if needed. Hansen's Tree Service has done previous grinding projects for the City and we have been pleased with their performance.

Thank you for your consideration.

CONTRACT AGREEMENT

STATE OF MISSOURI
COUNTY OF PETTIS

THIS AGREEMENT AND INDENTURE MADE AND ENTERED INTO THIS, the _____ day of _____, 2024 by and between the CITY OF SEDALIA, MISSOURI.

Party of the first part, termed in this agreement and the Contract Documents as the "CITY", and _____ Party of the second part, termed in this agreement and the Contract Documents as the "CONTRACTOR".

WITNESSETH:

THAT, WHEREAS, the City has heretofore caused to be prepared certain contract documents for furnishing material, personnel and performing work therein fully described, and the Contractor did, on the _____ day of _____, 2024 file with the City a copy of said contract documents together with his offer and proposal to furnish said material and perform said work at the terms therein fully stated and set forth; and,

WHEREAS, the said contract documents accurately and fully described the terms and conditions upon which the contractor is willing to furnish the materials, personnel and perform the work called for by the said contract documents and in the manner and time of furnishing and performing same,

IT IS, THEREFORE, AGREED:

1. That a copy of said contract documents filed as aforesaid be attached hereto and that the same do in all particulars become the agreement and contract between the parties hereto in all matters and things set forth therein and described; and further, that both parties hereby accept and agree to the terms and conditions of said contract documents so filed for the **Yard Waste Grinding 2024, Project 2025-004, dated June 14, 2024.**
2. The Contract Documents hereto annexed are made a part of this agreement and contract as fully and absolutely as if herein set out.
3. That the wages paid under this contract shall be not less than the prevailing rate of wages as determined by the Missouri State Division of Labor Standards.
4. This contract is executed in two (2) copies.

IN WITNESS WHEREOF, the parties hereto have executed this contract on the day and year in this agreement first above written.

ATTEST:

CITY OF SEDALIA, MISSOURI
(Party of the first part)

City Clerk

BY: _____
Kelvin Shaw
City Administrator

SEAL

(If a corporation)

ATTEST: _____
Secretary

SIGNATURE OF CONTRACTOR
(Party of the second part)

CONTRACTOR:

(CORPORATE SEAL)

BY: _____
(Name & Title)

(If an individual or partnership)

CONTRACTOR: _____

BY: _____
(Name & Title)

STATE OF _____

COUNTY OF _____

On this ____ day of _____, 2024 before me personally appeared _____ to me known to be the person described in and who executed the foregoing instrument and acknowledged that he/she executed the same as his/her free act and deed.

In Testimony Whereof, I have hereunto set my hand and affixed my official seal at my office in _____, the day and year first above written.

Notary Public

My Commission Expires:

PROPOSAL

TO THE CITY OF SEDALIA, MISSOURI:

Pursuant to and in compliance with the Notice to Contractors and having examined the plans and specifications with related documents and the site(s) of the proposed work, the undersigned bidder proposes and agrees, if this proposal is accepted, to furnish all labor, materials, tools, supplies, equipment and supervision and to do all other work necessary for the **YARD WASTE GRINDING 2024, Project 2025-004, dated June 21, 2024**, as noted in these contract documents for the following price(s):

| Item No. | Description | Unit | Unit Cost | Amount |
|----------|---|----------|-----------|----------|
| 1 | Yard Waste Grinding at City of Sedalia Compost Facility – 27882 Hwy. U, Sedalia, MO 65301 | Per Site | \$39,275 | \$39,275 |

Note, all costs to locate equipment to site, remove equipment from site, fuel, and labor are to be included and incorporated into the rate.

TOTAL AMOUNT OF BID: \$ \$39,275.00

Bidder acknowledges receipt of the following addenda, which has been considered in the preparation of this bid:

Addendum No. _____ Dated: _____

The undersigned agrees, if this proposal is accepted, to complete the work within **a period of 30 calendar days** from the date of the Notice to Proceed.

NAME OF BIDDER: Hansen's Tree Service.

BY: [Signature]

TITLE: VP

ADDRESS: 104 Hansen ct O'Fallon, mo 63366

DATE: 7-2-24

**Tabulation of Bids
Yard Waste Grinding
July 8, 2024 2:00 p.m.
Council Chambers**

| Description | Hansen's Tree Service 104 Hansen Court O'Fallon, MO 63366 | | Smithey Environmental Services, LLC 7298 Charles Page Blvd Tulsa, OK 74127 | | Hercules Weld and Fab, LLC 10500 Highway B Windsor, MO 65360 | |
|--|---|----------------------------|--|--------------------------|--|---------------------|
| | Unit Per Site | Unit Cost Amount | Unit Cost Amount | Unit Cost Amount | Unit Cost Amount | Unit Cost Amount |
| Yard Waste Grinding at City of Sedalia Compost Facility - 27882 Highway U, Sedalia, MO 65301 | | \$39,275.00 | \$2.50/Cubic Yard | \$2.50/Cubic Yard | \$225,000.00 | \$25,000.00/Day |
| TOTAL | | \$39,275.00 | | \$2.50/Cubic Yard | | \$225,000.00 |
| Anti-Collusion | | Yes | | Yes | | Yes |
| Bid Bond | | 5% Chk in lieu of bid bond | | No | | Yes |
| E-Verify | | Yes | | No | | No |
| Acknowledge Addendum 1 | | No | | Yes | | Yes |

BILL NO. _____

ORDINANCE NO. _____

AN ORDINANCE AUTHORIZING TASK ORDER NUMBER 3A FOR SMALL SANITARY SEWER PROJECT A.

WHEREAS, the City of Sedalia, Missouri has received Task Order Number 3A from Engineering Surveys and Services for engineering services related to the re-design of Small Sanitary Sewer Project A to improve the constructability; and

WHEREAS, Under the Task Order, the City of Sedalia, Missouri shall pay the sum and amount of Twenty One Thousand Three Hundred Dollars (\$21,300.00) for design and bid phase and Nineteen Thousand Three Hundred Dollars (\$19,300.00) for the construction phase to Engineering Surveys and Services as more fully described in Task Order Number 3A attached to this Ordinance and incorporated by reference herein.

NOW THEREFORE, BE IT ORDAINED BY THE COUNCIL OF THE CITY OF SEDALIA, MISSOURI, as follows:

Section 1. The Council of the City of Sedalia, Missouri, hereby approves and accepts Task Order number 3A by and between the City of Sedalia, Missouri and Engineering Surveys and Services, in substantively the same form and content as it has been proposed.

Section 2. The Mayor or City Administrator are authorized and directed to execute and the City Clerk is hereby authorized and directed to attest and fix the seal of the City of Sedalia, Missouri, on the document in substantively the same form and content as it has been proposed.

Section 3. The City Clerk is hereby directed to file in his office a duplicate or copy of the Task Order after it has been executed by the parties or their duly authorized representatives.

Section 4. This ordinance shall take effect and be in full force and effect from and after its passage and approval.

Read two times by title, copies of the proposed ordinance having been made available for public inspection prior to the time the bill is under consideration by the Council and passed by the Council of the City of Sedalia, Missouri this 5th day of August 2024.

Presiding Officer of the Council

Approved by the Mayor of said City this 5th day of August 2024.

ATTEST:

Andrew L. Dawson, Mayor

Jason S. Myers
City Clerk



Let's Cross Paths

City of Sedalia

200 S. Osage

Sedalia, MO 65301

(660) 827-3000 www.sedalia.com

To: Kelvin Shaw, City Administrator
Through: Chris Davies, City Engineer
From: Jeremy Stone, Public Works Project Manager
Date: July 23, 2024
Subject: RFQ 2023-001A Small Sanitary Sewer Project A-Task Order No. 3A

Engineering Surveys and Services (ES&S), was contracted for the design of the above mentioned project for a gravity sanitary sewer main extension to WireCo to be able to connect to City sewer. The project was designed and bids were publicly opened on May 30, 2024 and no bids were received. After discussing with contractors, City staff, and the design engineers, a re-design is necessary to improve the constructability of this project. Attached is the scope and fee provided from Engineering Surveys and Services to re-design the sanitary sewer extension to include a force main as well as an alternate gravity sewer main alternate.

The attached scope and fee details the fee for design and bid phase for \$21,300.00 and the construction phase services for \$19,300.00. This re-design would be complete and ready for advertisement for bid within 60 days of notice to proceed. City staff recommends the approval of this change order.

Thank you for your consideration.



**EXHIBIT A: SCOPE OF WORK -
TASK ORDER – NO. 3A
TO
AGREEMENT BETWEEN OWNER AND ENGINEER
FOR
PROFESSIONAL SERVICES
BETWEEN**

City of Sedalia ("Owner"),

Engineering Surveys and Services LLC ("Engineer").

This Task Order becomes an attachment to the following Agreement:

Master Services Agreement for Professional Engineering and Consulting Services

between Owner and Engineer effective as of February 6, 2023 ("Effective Date").

The Task Order, of which Engineer's services under this Agreement are a part, is generally identified as follows:

Small Sewer Project A

(Task Order)

This Task Order #3A is a revision to the previously prepared Task Order #1 which was for approximately 465 linear feet of 8-inch diameter sanitary sewer pipe plan set (dated 1/18/2024) that was sent out to bid, and had a bid opening on May 30, 2024 for the Small Sewer Project A. The proposed plan included a gravity sanitary sewer installation extending from existing manhole A-1 on the Central Region Lift Station project northward, under the Missouri Pacific railroad, and terminating at a new manhole just north of the Missouri Pacific Railroad right-of-way, on the WireCo property. This Task Order #3A includes the efforts to revise that plan converting the gravity sanitary sewer to a forcemain and a pump station on the WireCo property north of the Missouri Pacific railroad and rebidding with the forcemain option and the gravity sanitary sewer option as an alternate. The gravity sanitary sewer alternate option will be revised from the previous gravity plan by lowering the gravity line such that the railroad crossing is deep enough to not require RailPros track monitoring. The portions of the previous Task Order #1 that were completed are not included here. Items that need to be completed again are included in this Task Order #3A as well as items that have not occurred yet in Task Order #1. This Task Order #3A shall override any outstanding work of Task Order #1.

Engineer shall furnish to the Owner the following services:

Scope of Work Task Summary

1. Data Collection
 - 1.1. Kick-Off Meeting

2. Design and Construction Documents
3. Bid Phase Services
4. Construction Phase Services
 - 4.1. Engineering Observation
 - 4.2. As-Built Record Drawings

Detailed Scope of Work Tasks

1. Data Collection The services provided in this section shall include:

1.1. Project Kick-Off Meeting: Engineer will attend a meeting with Public Works staff prior to the start of preliminary design to review operational needs, design criteria, and approval requirements. Prior to the meeting the Owner will provide the Engineer with available project data necessary to complete the design of the project. Information to be provided by the Owner shall include, but is not limited to:

- 1.1.1. Proposed forcemain and lift station capacity requirements (cubic feet per second) or information from WireCo about water usage/employee counts.
- 1.1.2. Future planning considerations for lift station and forcemain.

2. Design and Construction Documents The services provided in this section shall include:

2.1. Utility Coordination:

- 2.1.1. PDF copies of the preliminary plans will be provided to the utility companies as the project progresses.
- 2.1.2. Prepare two construction plan documents for the forcemain with lift station and revised gravity sewer based on the alignment and/or construction techniques approved by Owner.
- 2.1.3. Specify a Package Lift Station and prepare pump duty point calculations.

2.2. Submit 50-percent and 90-percent design documents to Public Works for review for both the forcemain with lift station option and revised gravity sewer plan option. Engineer will attend review meetings as required and at the 50-percent and 90-percent design stages.

2.3. The Engineer's Opinion of Probable Construction Cost is to be provided at the 90- and 100-percent completion stage for both the forcemain with lift station option and revised gravity sewer plan option.

2.4. Prepare final design bid packages for construction. Final design bid package is to include drawings, Kansas City Metro Chapter APWA technical specifications Section 2500 and Section 5500, and Engineers Joint Contract Documents Committee front-end bid documents (Project Manual). The Engineer shall prepare a single Project Manual that

covers the forcemain as the primary bid option with the revised gravity plan as the alternate.

2.5. AutoCAD will be used for all contract drawings. Drawings will be on 24 x 36-inch sheets.

2.6. Permitting. Engineer shall prepare/revise:

2.6.1. Union Pacific Rail Road pipeline crossing permit.

3. **Bid-Phase Services** The services provided in this section shall include:

3.1. Assist Owner with scheduling and conducting a prebid conference. Prepare minutes of the meeting and submit to Public Works.

3.2. Print one (1) set of the bid documents to use at the meeting.

3.3. Respond to bidder's questions during the bidding period.

3.4. Prepare bid addenda, as needed.

3.5. Attend bid opening and assist with bid evaluation/recommendation.

3.6. Engineer shall provide the Owner the bid documents for them to distribute as desired.

4. **Construction-Phase Services** (Construction is anticipated to have substantial completion in less than 60 calendar days and final completion in less than 90 calendar days) The services provided in this section shall include:

4.1. Attend the Pre-Construction meeting and prepare meeting minutes

4.2. Construction Inspection – Engineer shall provide the following services for the project duration:

4.2.1. A representative will be at the jobsite while sewer line, manhole construction, and lift station testing are in progress and during other critical phases of the work. We estimate 30 site visits by an inspector with an average of 4 hours per site visit and 12 site visits by a professional engineer with an average of 2 hours per visit. Engineering Surveys and Services will do site visits and inspections up to the substantial completion date. Between substantial completion and final completion the inspections will be done by the City of Sedalia.

4.2.2. An engineer will visit the jobsite throughout construction to perform inspection quality control checks.

4.2.3. A professional engineer will have regular contact with the field inspector via phone/e-mail to discuss daily activities.

4.2.4. A professional engineer will be involved with resolving any contractor questions.

4.2.5. Daily field inspection documentation will be maintained in a project diary and on field sets of plans.

- 4.2.6. A professional engineer will be onsite during critical operations, manhole testing, etc.
- 4.2.7. Document manhole and sewer pipe testing. Construction contractor will be required to provide all test equipment and to perform the tests.
- 4.2.8. A professional engineer will review reports, shop drawing paperwork, contractor schedules, quantities, pay requests, etc.
- 4.3. Construction Materials Testing: Construction materials testing is not anticipated on this project. Any required testing will be performed by Engineer under separate agreement.
- 4.4. As-Built Record Drawings. Perform post construction survey and prepare As-Built Plans/CAD file:
 - 4.4.1. Receive the construction contractor's certified record drawing revisions.
 - 4.4.2. Field survey the tops and flowlines of all new sanitary sewer manholes.
 - 4.4.3. Supply Public Works with full-size reproducible record drawings and an AutoCAD digital version of the record drawings.

Additional Services

The following services can be provided as additional services:

1. Off site design
2. Revision to existing or additional easement preparation
3. USACE permit (already acquired)
4. Missouri DNR Land Disturbance Permit (not required for less than 1 acre disturbed)
5. Missouri DNR Construction Permit For Sanitary Sewer Extension/Lift Station
6. Stormwater Pollution Prevention Plan
7. Funding applications, Engineering Reports (e.g., SRF)
8. Environmental clearance documentation
9. Easement acquisition services
10. Construction materials testing
11. Construction Phase Contractor ARPA Requirements Monitoring
12. Site Visits or Inspections After Substantial Completion

The individual point(s) of contact for this task order, if different from those undersigned, shall be:

OWNER:

Kelvin Shaw – City Administrator
PH: (660) 827-3000 Ext. 1102
EML: kshaw@sedalia.com

ENGINEER:

Kelly Lohsandt
Kelly Lohsandt, P.E.
PH: (573) 821-4605
EML: klohsandt@ess-inc.com

Design services shall be completed within 60 days of notice to proceed.

For Tasks 1 through 3 (Data Collection, Design and Construction Documents and Bid Phase Services), Owner will compensate Engineer for services performed on a fixed fee cost of \$ 21,300. Basis of payment to Engineer shall be as outlined in the Agreement using the current "Hourly Fee Schedule" shown as EXHIBIT B.

For Task 4 (Construction Phase Services) Owner will compensate Engineer for services performed on a time and material expended basis up to a maximum not to exceed cost of \$ 19,300. Basis of payment to Engineer shall be as outlined in the Agreement using the current "Hourly Fee Schedule" shown as EXHIBIT B.



**Professional Services
Hourly Fee Schedule**

April 1, 2024

| SERVICE OF: | RATE: |
|--|----------------|
| Principal | \$ 180 / hour |
| Senior Professional Engineer | \$ 170 / Hour |
| Professional Engineer | \$ 150 / hour |
| Engineer Intern | \$ 115 / hour |
| Professional Land Surveyor | \$ 150 / hour |
| Senior Project Manager | \$ 125 / hour |
| Senior Design Technician | \$ 100 / hour |
| Technician (Survey or CAD) | \$ 85 / hour |
| Concrete Technician | \$ 70 / hour |
| Soils Technician | \$ 75 / hour |
| Special Inspector | \$ 90 / hour |
| Survey Crew Chief | \$ 95 / hour |
| AWS Certified Weld Inspector (Senior) | \$ 150 / hour |
| AWS Certified Weld Inspector | \$ 95 / hour |
| Chemist | \$ 75 / hour |
| Administrative Assistant | \$ 64 / hour |
| Laser Scanning Equipment | By Quote |
| UAS (Drone) w/ pilot | \$ 150 / hour |
| Survey - Stakes | \$ 0.30 / each |
| Survey – Iron Pins | \$ 3.50 / each |
| Survey – Fence Posts | \$ 7 / each |
| Drill Rig and other equipment | By Quote |
| Large Format Copies | \$ 4.00 / each |
| Photocopies - | |
| 8 ½" x 11" single-sided, black & white | \$ 0.30 / each |
| 8 ½" x 11" single-sided, color | \$ 0.60 / each |
| 11" x 17" single-sided, black & white | \$ 2.00 / each |
| Travel | \$ 0.65 / mile |
| Per Diem | \$ 50 / day |
| Lodging | Cost |

NOTES:

1. Overtime charges at 1.5 times above rates.
2. Scheduled construction phase services and/or field observations will be charged at a 2-hour minimum.
3. Weekend work will be charged at 2-hour minimum overtime.

BILL NO. _____

ORDINANCE NO. _____

AN ORDINANCE APPROVING AND ACCEPTING A QUOTE FOR THE PURCHASE OF TWO DAY CAB TRUCKS.

WHEREAS, The City of Sedalia, Missouri, has received a quote from H Crane LLC, dba Hannibal Crane Service for the purchase of two Kenworth T800 Day Cab Trucks, wet kit included for the Street Department; and

WHEREAS, under the terms of the Quote, the City of Sedalia shall pay the sum and amount of Sixty-five Thousand Dollars (\$65,000.00) to H Crane LLC, dba Hannibal Crane Service for said truck as more fully described in the quote attached to this Ordinance and incorporated by reference herein.

NOW THEREFORE, BE IT ORDAINED BY THE COUNCIL OF THE CITY OF SEDALIA, MISSOURI, as follows:

Section 1. The Council of the City of Sedalia, Missouri, hereby approves and accepts the quote from H Crane LLC, dba Hannibal Crane Service in substantively the same form and content as the quote has been proposed.

Section 2. The Mayor or City Administrator are authorized and directed to execute and the City Clerk is hereby authorized and directed to attest and fix the seal of the City of Sedalia, Missouri, on any other documentation, if necessary, in substantively the same form and content as the quote has been proposed.

Section 3. The City Clerk is hereby directed to file in his office a duplicate or copy of the quote and any other subsequent documentation after it has been executed by the parties or their duly authorized representatives.

Section 4. This ordinance shall take effect and be in full force and effect from and after its passage and approval.

Read two times by title, copies of the proposed ordinance having been made available for public inspection prior to the time the bill is under consideration by the Council and passed by the Council of the City of Sedalia, Missouri this 5th day of August, 2024.

Presiding Officer of the Council

Approved by the Mayor of said City this 5th day of August, 2024.

ATTEST:

Andrew L. Dawson, Mayor

Jason S. Myers, City Clerk



Let's Cross Paths

City of Sedalia

200 S. Osage

Sedalia, MO 65301

(660) 827-3000 www.sedalia.com

To: Kelvin Shaw, City Administrator
Through: Matthew Wirt, Assistant City Administrator
From: Justin Bray, Public Works Operations Director
Date: July 30, 2024
Subject: Two Used Day Cab Semi-truck with Wet Kit for Public Works Street Division

The Public Works Department FY25 budget included purchasing a used day cab tractor for hauling the increased demand of heavy loads. The loads include asphalt, large equipment for paving, road salt, 5-ton concrete blocks for parades, and multiple other items too heavy for pickups or dump trucks. During the search I found two quality used tractors for the amount budgeted for one. The increased capability of two tractors will allow the department to haul the ever-increasing large loads and supplies for projects. In addition, as our equipment is growing in size and capability DOT regulations require vehicles with higher gross vehicle ratings like those in day cab tractors. As a result, I request the purchase of the two Kenworth T800 tractors from H Crane LLC DBA Hannibal Crane Service, 7060 Hilltop Parkway, Hannibal, MO 63401.

H Crane LLC DBA Hannibal Crane Service –

2012 Kenworth T800 Day Cab wet kit included - \$37,000.00

2013 Kenworth T800 Day Cab wet kit included - \$37,000.00

If both trucks are purchased take off and additional \$9,000.00 for a total cost of \$65,000.00

Below is a comparable truck in similar condition.

Asbury Farms-Missouri

1999 Kenworth T800 Day Cab wet kit included - \$45,000.00

S&I-Michigan

2012 Kenworth T800 Day Cab wet kit included - \$92,500.00

Reagan Enterprises Inc-Missouri

2012 Kenworth T800 Day Cab wet kit included - \$59,900.00

RECOMMENGATION: It is Public Works Street Division's recommendation that the City Council approves (2) Kenworth T800 Day Cab wet kit included from H Crane LLC DBA Hannibal Crane, for \$65,000.00.

H Crane LLC DBA Hannibal Crane Service
7060 HILLTOP PARKWAY
HANNIBAL, MO 63401
+15734060105
melissa@hannibalcrane.com
www.hannibalcrane.com



ADDRESS
City of Sedalia
200 South Osage
Sedalia, MO 65301

Estimate 24-050

DATE 07/30/2024

| SERVICE DATE | ACTIVITY | QTY | RATE | AMOUNT |
|--------------|--|-----|-----------|--------------------|
| | Services 2012 Kenworth T800 Day Cab Wet Kit Included | 1 | 37,000.00 | 37,000.00 |
| | Services 2013 Kenworth T800 Day Cab Wet Kit Included | 1 | 37,000.00 | 37,000.00 |
| | Services Discount if purchasing together | 1 | -9,000.00 | -9,000.00 |
| TOTAL | | | | \$65,000.00 |

Accepted By

Accepted Date

**CITY COUNCIL
OF THE CITY OF SEDALIA, MISSOURI**

RESOLUTION NO. _____

**A RESOLUTION OF THE CITY COUNCIL OF THE CITY OF SEDALIA, MISSOURI,
STATING FACTS AND REASONS FOR THE NECESSITY TO AMEND AND INCREASE
THE CITY'S ANNUAL BUDGET FOR FISCAL YEAR 2025.**

WHEREAS, Section 67.010 of the Revised Statutes of Missouri requires each political subdivision of the State of Missouri ("State") to prepare an annual budget and establishes the requirements for that budget; and

WHEREAS, the City of Sedalia, Missouri ("City"), is a city of the third classification created pursuant to Chapter 77, RSMo, and is a political subdivision of the State of Missouri; and

WHEREAS, the City Council of the City adopted and approved the City's annual budget for Fiscal Year 2025 in accordance with the requirements of Section 67.010, RSMo, by Ordinance No. 11990 on March 18, 2024, and

WHEREAS, Sections 67.030 and 67.040 authorize and provide a procedure for the City Council to amend the City's annual budget to increase expenditures in any fund; and

WHEREAS, expenses for City's operations for Fiscal Year 2025 have been higher than budgeted, but do not exceed revenues plus the City's unencumbered balance brought forward from previous years; and

WHEREAS, the City Council of the City desire to state the facts and reasons necessitating an amendment to increase certain expenditures in the Fiscal Year 2025 annual budget.

NOW THEREFORE, BE IT RESOLVED BY THE CITY COUNCIL OF THE CITY OF SEDALIA, MISSOURI, AS FOLLOWS:

Section 1. Expenditures from the City's WPC Fund must be increased by a total of \$370,920 above the amount authorized in the adopted annual budget for Fiscal Year 2025. An amendment to increase said budget is necessary for the following facts and reasons:

- A. Purchase two blowers and associated equipment.

Section 2. This Resolution shall take effect immediately upon its execution by the Mayor or otherwise as provided by law.

PASSED by the City Council of the City of Sedalia, Missouri, on August 5, 2024

Presiding Officer of the Council

ATTEST: _____
Jason S. Myers, City Clerk

BILL NO. _____

ORDINANCE NO. _____

AN ORDINANCE AMENDING THE BUDGET FOR THE FISCAL YEAR 2024-2025 REGARDING WPC BLOWER PURCHASES.

NOW THEREFORE, BE IT ORDAINED BY THE COUNCIL OF THE CITY OF SEDALIA, MISSOURI as follows:

Section 1. The 2024-2025 fiscal year budget beginning April 1, 2024 and ending March 31, 2025 is hereby amended to modify certain budgeted line items as they appear on the attached schedule and made a part hereof as Exhibit A as if fully set out herein.

Section 2. This ordinance shall be in full force and effect from and after its passage and approval.

Read two times by title, copies of the proposed ordinance having been made available for public inspection prior to the time the bill is under consideration by the Council and passed by the Council of the City of Sedalia, Missouri this 5th day of August 2024.

Presiding Officer of the Council

Approved by the Mayor of said City this 5th day of August 2024.

Andrew L. Dawson, Mayor

ATTEST:

Jason S. Myers
City Clerk

Exhibit A
 City of Sedalia
 FY25 Budget Amendment 8/5/2024 WPC Blower Purchases

| Account / Description | Current Budget | Change | Amended Budget | Comments |
|-------------------------------------|----------------|---------------------|----------------|--|
| Expenditures / Uses of Funds | | | | |
| 61-51-351-00 Equipment | 437,628.72 | 370,920.00 | 808,548.72 | Purchase 2 Turbo Blowers and Associate Equipment |
| Total Expenditure Change | | <u>370,920.00</u> | | |
| | | <u>(370,920.00)</u> | | Net Increase (Decrease) In Projected Fund Balance |

BILL NO. _____

ORDINANCE NO. _____

AN ORDINANCE APPROVING AND ACCEPTING A QUOTE FOR THE PURCHASE OF TWO TURBO BLOWERS FOR THE SOUTHEAST WASTEWATER TREATMENT PLANT.

WHEREAS, the City of Sedalia, Missouri has received a proposal from FTC Equipment, LLC for the purchase of two Sulzer HST Turbocompressor blowers and associated equipment for the Southeast Wastewater Treatment Plant; and

WHEREAS, under the proposal, the City of Sedalia, Missouri shall pay FTC Equipment, LLC the sum of Three Hundred Seventy Thousand Nine Hundred Twenty Dollars (\$370,920.00) as more fully described in the quote attached to this Ordinance and incorporated by reference herein.

NOW THEREFORE, BE IT ORDAINED BY THE COUNCIL OF THE CITY OF SEDALIA, MISSOURI as follows:

Section 1. The Council of the City of Sedalia, Missouri hereby approves and accepts the Quote by and between the City of Sedalia, Missouri and FTC Equipment, LLC as the quote has been proposed.

Section 2. The Mayor or City Administrator are authorized and directed to execute and the City Clerk is hereby authorized and directed to attest and fix the seal of the City of Sedalia, Missouri on the quote in substantively the same form and content as the quote has been proposed.

Section 3. The City Clerk is hereby directed to file in his office a duplicate or copy of the quote after it has been executed by the parties or their duly authorized representatives.

Section 4. This Ordinance shall be in full force and effect from and after its passage and approval.

Read two times by title, copies of the proposed Ordinance having been made available for public inspection prior to the time the bill is under consideration by the Council and passed by the Council of the City of Sedalia, Missouri this 5^h day of August, 2024.

Presiding Officer of the Council

Approved by the Mayor of said City this 5^h day of August, 2024.

Andrew L. Dawson, Mayor

ATTEST:

Jason S. Myers, City Clerk

MEMO

TO: Kelvin L. Shaw, City Administrator
Matthew Wirt, Assistant City Administrator
Jessica Pyle, Finance Manager

CC: Jason Myers, City Clerk
William Bracken, Utilities Director

FROM: Christopher R. Davies P.E., City Engineer

DATE: August 1, 2024

**SUBJECT: AUTHORIZATION TO PURCHASE TURBO BLOWERS FOR
SOUTHEAST WWTP**

Background:

As you are aware the City is under an Abatement Order of Consent (AOC), Order No. 2024-WPCB-1873 to make improvements for the Central and North WWTP so they comply with the issued NPDES Permit from DNR. The City engaged the professional services of Burns & McDonnell to do a "Design & Build" for the first phase of the improvements for the Central WWTP, which was the upgrade to the aeration basin. The improvements include: 1) new mixer, 2) new diffusers, 3) new blowers and building for the blowers; and 4) associated equipment.

The Southeast WWTP also uses the same technology to provide air to the processing of the material. As discussed during the Central WWTP upgrade, the same holds true at the Southeast WWTP, with the exception the blowers have smaller motors:

"Blowers are an essential part of the upgrade to the aeration basin. The blowers provide air into the basin to maintain the processing of the material. Currently the City uses three (3) Positive Displacement (PD) blowers to accomplish this task. There are two options for the City to consider when replacing the blowers: 1) replace in-kind (PD blowers) or 2) Turbo Blowers. The major differences between the two types of blowers are: 1) routine maintenance – Turbo blowers have less moving parts and easier to maintain; 2) Turbo blowers use less electricity since they have variable speed motors and PD blowers have a one speed motor – therefore the Turbo blowers will adjust their speed based on the load that is required.

We asked Burns and McDonnell to compare the differences between the two types of blowers and staff made the recommendation to move forward with the Turbo blowers."

Discussion:

As mentioned above, the Southeast WWTP, has three (3) blowers which provide air to the processing of the material. All three (3) of these blowers have failed; however staff with the assistance of FTC, was able to get one of them operational. In addition, staff was able to find a blower to rent, thereby meeting the minimum number of blowers required by MoDNR. After inspection of the equipment (blowers) it was determined the best course of action was to replace two (2) of the blowers at this time for the following main reasons:

1. During the design/build process at Central WWTP, the City went through a thorough review of the possible options and made the decision to purchase the Turbo blowers.
2. Lower operational costs.
3. Consistency in maintenance and equipment.

Based on these facts and our commitment made, we contacted FTC Equipment LLC, the City's current contractor for maintenance of pumps and motors for the water/wastewater plants, and asked them to provide a price for the blowers. FTC provided the City with a quotation of \$370,920.00, quote and additional information is attached.

NOTE:

1. The purchase of a 3rd blower for Southeast WWTP, is being put on-hold until we determine what the best option is: 1) purchase the same type of blower and make it permanent, or 2) purchase a portable "trailer mounted blower", which is then available for any WWTP.
2. As the City moves forward with the design/build of the North WWTP, we will be using the same type of blowers, based on what we know now, to stay consistent.

Please let me know if you need any additional information or have any questions.

Recommendation:

It is staff's recommendation that City Council approve the purchase of two (2) Sulzer Turbo Blowers and associated equipment directly from FTC Equipment, LLC for a \$370,920.00.



Sedalia, MO - SE WWTP

Proposal to replace current HSI Turbo Blowers

FTC Proposal for Sulzer HST Turbocompressors

Prepared By:

Ryan Quick

FTC Equipment, LLC

5238 Winner Rd.

Kansas City, MO 64127

Ph: 816-833-7200



QUOTATION

Attn: William Bracken
Company: Sedalia, MO -City of
Ph No.: 660-596-5719
E-Mail: wbracken@sedalia.com

From: Ryan Quick
Company: FTC Equipment
Ph No.: (816) 686-1915
E-Mail: ryanq@ftcequipment.com

Prepared By: Sydney O'Brien
Ph No.: (816) 833-7200

Subject: Sedalia SE WWTP

| | |
|---|--------------|
| Quote No. | 2024-Q062-R2 |
| DATE | 31-Jul-24 |
| CPT: Sedalia, MO | |
| Sulzer's Standard Distributor Commercial Terms Apply | |
| Prices are in USD. Pricing based on assumed delivery of 2025 | |
| Delivery To Be Advised on Notice to Proceed | |
| Submittals: 2 - 4 weeks | |
| Validity: 30 Days | |

| Item | Qty | Description | Subtotal |
|------|-----|---|----------|
| 1 | | High Speed Turbo Blowers | |
| | | Configuration is 2 operating plus 0 standby | |
| | 2 | Turbo Compressor HST 2500-U100-1-L-48, 480/3/60 | |
| | 2 | Ethernet/IP (Ethernet) Communication | |
| | 1 | Master Control Unit (MCU) | |
| | | Inlet Accessories | |
| | 2 | Rainhood - Square (used w/ INF-SS only) - 304SS | |
| | 2 | Inlet Filter (INF), Process Air, Square - 304SS | |
| | 2 | Inlet Filter Adapter (used w/ SQ INF/Piping) - 214.4 mm Pipe - 304SS | |
| | 2 | Inlet Pipe Extension (used w/ Flanged Piping) - DN 200 x 219.1 mm Dia | |
| | 2 | Inlet Flanged Silencer (used w/ Flanged Piping) - DN 200 x DN 200 | |
| | 2 | Inlet Bellows Joint (used w/ Flanged Piping) - DN 200 x DN 200 | |
| | 2 | Inlet Scrap Trap - Wafer, DN 200 | |
| | 2 | Pressure Differential Switch - US Units | |
| | | Outlet Accessories | |
| | 2 | Outlet Flexible Joint - DN 125 x DN 125 | |
| | 2 | Outlet Combined Diffuser Cone Silencer - DN 125 x DN 200 | |
| | 2 | Back Flow Barrier, Dual Flapper Type - Wafer, DN 200/8" ANSI | |
| | 2 | Manual Outlet Valve - Wafer, DN 200/8" ANSI | |
| | | Other Accessories | |
| | 2 | Blow-Off Silencer - 160 mm Dia Duct | |
| | 2 | Motor Cooling Air Silencer - 160 mm Dia Duct | |
| | 2 | Outlet Cone Insulation - Covers OFJ & Outlet Cone | |
| | | Spare Parts | |
| | 2 | Inlet Filter Cartridge - ITFL (4 / blower) | |
| | 2 | Cabinet Cooling Air Filters (3 / blower) | |
| | | Factory Testing | |
| | 2 | Non-Witness Testing - Per Factory Standard | |
| | 2 | Additional Test Points - Per Factory Standard | |
| | 2 | Balancing Report | |
| | 2 | Hydrostatic Pressure Test Certificate | |
| | 2 | Factory Certificates | |
| | 2 | Noise Certificate | |
| | 2 | Transport Packaging by Sea | |
| | 2 | Accessories Packaging | |
| 2 | | Start-Up Assistance & Training - Warranty - Freight | |
| | 1 | Commissioning (Start up & Training) for HST, 3 Days On Site | |
| | 1 | Commissioning (Start up & Training) for MCU, 3 Days On Site | |
| | 2 | Standard Warranty (2 years) | |
| | 1 | Freight, USA to Sedalia, MO | |



QUOTATION

Attn: William Bracken
Company: Sedalia, MO -City of
Ph No.: 660-596-5719
E-Mail: wbracken@sedalia.com

From: Ryan Quick
Company: FTC Equipment
Ph No.: (816) 686-1915
E-Mail: ryanq@ftcequipment.com

Prepared By: Sydney O'Brien
Ph No.: (816) 833-7200

Subject: Sedalia SE WWTP

| | |
|---|--------------|
| Quote No. | 2024-Q062-R2 |
| DATE | 31-Jul-24 |
| CPT: Sedalia, MO | |
| Sulzer's Standard Distributor Commercial Terms Apply | |
| Prices are in USD. Pricing based on assumed delivery of 2025 | |
| Delivery To Be Advised on Notice to Proceed | |
| Submittals: 2 - 4 weeks | |
| Validity: 30 Days | |

| Item | Qty | Description | Subtotal |
|------|-----|--|--------------------------------|
| | | Please note that start-up trips quoted above assume all blowers quoted will be installed and prepared for start-up at the time of the first visit. | |
| | | Quoted commissioning does not take into consideration a phased or sequenced start-up unless otherwise noted and is not intended for project management or project timeline purposes. Any defects in Sulzer blower's material or craftsmanship that would require additional start-up days or trips will be done at the expense of Sulzer. Any delays in start-up due to influences outside of Sulzer's control that would require additional field services will be billed at a rate of \$2,400 per day. | |
| | | Additionally, note that Start-Up Assistance & Training & Freight must be included in the final price. These items can not be discounted nor commissioned. Additional Field Services are available at \$2,400.00/day | |
| | | Total Air Flow Range (SCFM): 3,408 | |
| | | Differential Pressure (psi): 7.00 | |
| | | Altitude (ft ASL): 801 | |
| | | Inlet pressure (psia): 14.22 | |
| | | Inlet pressure losses (psi): 0.06 | |
| | | Process air inlet temp. range (° F): 0 to 105 | |
| | | Relative humidity range (%): 36 to 90 | |
| | | Site Voltage / Phase / Freq: 480/3/60 | |
| | | SULZER ABS will provide the following Type of MCU for this project: A-B CompactLogix PLC and 7" PanelView Plus7 touch screen interface | |
| | | The above MCU shall include the following elements: | |
| | | 1) MCU Enclosure, NEMA 4 sheet steel. | |
| | | 2) Allen Bradley PLC containing the software to control the HST Blowers | |
| | | 3) MCU includes 16 Digital Inputs, 16 Digital Outputs, 4 Analog Inputs, 2 Analog Outputs, 24 VDC Power Supply and UPS @ 3.4 AH | |
| | | 4) A-B Ethernet Communications between the PLC and HMI and for Inter-PLC/SCADA communications using CAT5/6 cabling. | |
| | | CAT 5/6 cabling by others. No Fiber Optic Equipment included. | |
| | | 5) Ethernet/IP communications between the MCU and the HST Blowers | |
| | | 6) Allen Bradley 8 Port Unmanaged Ethernet Switch | |
| | | 7) Manifold Pressure Control (Pressure Monitoring Device not included) | |
| | | 8) Control of a maximum of (2) HST Blowers using a PID controller | |
| | | | Pricing based on 2025 delivery |
| | | Total Project NET Price | \$ 370,920.00 |

Clarifications / Exceptions Statement

- 1) Sulzer's standard distributor commercial terms apply.
- 2) The *Build America and Buy America Act* (BABA) included in the *Infrastructure Investment and Jobs Act*, Pub. L. 117-58, §§ 70911 – 70917, requires, with exception, that funds made available for a Federal financial assistance program for infrastructure may not be obligated for a project unless all of the iron, steel, manufactured products, and construction materials used in the project are produced in the United States. Currently, Sulzer makes no general warranties as to its products' compliance with the BABA. Additional guidance continues to be issued by Federal agencies pertaining to the implementation of BABA. Upon request, Sulzer will consider specific requests for product certifications according to applicable project requirements and available guidance from the relevant agency. Sulzer supplies products that comply with many domestic preference rules. If any specific sourcing requirements are applicable to this project, Sulzer will be glad to review and respond in regard to its products' compliance with the particular contract requirements.
- 3) Sulzer has not received or reviewed any project specifications, plans, or drawings.
- 4) Sulzer is offering this blower to match the performance requirements provided to Sulzer via email. Sulzer has included accessories to match the inlet and outlet configuration style that was supplied with previous the Sedalia, MO project, Sulzer Order 935170.
- 5) Check valve is intended for installation with horizontal airflow, which reduces pressure loss through the valve and ensures smooth operation at low airflows.
- 6) Sulzer has included start-up service to field commission 2 Blowers and 1 Master Control Unit (MCU), and other accessories included in our scope of supply and provide integration support between the HST Blower and MCU for a maximum of Six (6) Days over Two (2) Trips as described in our quotation. Any additional service days required will incur an additional charge by Sulzer. In addition, Sulzer can only be responsible for components supplied in their scope of supply to ensure a functioning system.
- 7) Please note that a Pressure Differential Switch will be supplied and needs to be installed on the Inlet Filter and wired back to the HST Blower Enclosure Control Terminal.
- 8) Power wiring and Ground wiring needs to be sized per NEC and local codes.

TECHNICAL QUOTATION REMARKS SULZER TURBOCOMPRESSOR HST

Each Sulzer HST Turbocompressor is offered with the following standard package features and accessories included.

- 1) High Speed Unit including with Impeller, Motor, Labyrinth Seal, Magnetic Bearing System mounted on a skid
- 2) Temperature sensors for inlet and outlet, motor, VFD & MBC
- 3) Pressure sensors for inlet and outlet
- 4) Differential pressure switch for inlet filter high pressure notification
- 5) Built in flow (via algorithm) and speed measurement
- 6) Volute with Inlet & Outlet flanges
- 7) Magnetic Bearing Controller, MBC-12
- 8) High Performance Vacon NX VFD
- 9) RFI Filter & AC Choke
- 10) Blow Off Valve, electro-pneumatically controlled plug type
- 11) Control Cabinet with power interlock switch.
- 12) Control Cabinet with local detachable Keypad or with full HMI undetachable Display.
- 13) Acoustic Noise Enclosure (see appendix for guaranteed dB(A))
- 14) UPS for Magnetic Bearing Controller
- 15) Technical Specification, Cut Sheets, Installation Manual, Commissioning, Manual, Operators Manual, Layout Drawings & Accessory Drawings

Factory Performance Test, with each blower, non-witnessed, in conformance with abridged ISO 5389:1992 -Turbocompressors, VDI 2045:1993 – Acceptance and Performance Tests on Turbocompressors & Displacement Compressors. Optional full ISO 5389, ASME PTC-10, or ASME PTC-13 in addition to optional Witness Test.

TERMS AND CONDITIONS: Sulzer Standard Terms & Conditions apply.

TECHNICAL QUOTATION REMARKS SULZER TURBOCOMPRESSOR HST

Comments & Exceptions:

- 1) Above items only; additional accessories available upon request.
- 2) No special tools are required
- 3) Sulzer's standard product is offered.
- 4) Anchor bolts are not included
- 5) Supply and installation of interconnecting communications cabling between each turbocompressor and the MCU (if supplied).
- 6) Installation of compressor units, blower accessories and associated pipe work
- 7) Supply and installation of electrical power and signal cables to each turbocompressor and the MCU (if supplied)
- 8) Provision of any further instrumentation other than that contained within each turbocompressor or the MCU (if supplied). This also excludes the pressure, flow or D.O. transducer required to generate the 4-20ma signal for compressor control.
- 9) Pipe insulation as deemed necessary by the client to prevent contact with hot pipes.
- 10) Reasonable access to the site and working area to enable continuous installation.
 - 11) Free access to facilities
 - 12) The compressors are to be installed in a compressor room constructed by others.
 - 13) The compressor room floor will be flat and level to standard civil tolerances.
 - 14) That the Sulzer Turbocompressor HST can be off loaded and placed directly into the compressor building
- 15) Cable tray or ducts to each compressor for the communications cabling will be supplied and installed by others.
- 16) The above price does not include sales tax or other costs unless specifically included in this proposal.

This quote and any accompanying documents contain information belonging to Sulzer which is confidential and legally privileged. This information is intended only for the use of the individual or entity to whom this transmission was sent as indicated above. Copying or disseminating this communication without the express permission of Sulzer is prohibited. If you are not the intended recipient, any disclosure, copying, distribution, or action taken in reliance on the contents of the information contained in this transmission is strictly prohibited.

Appendix

- 1) Performance Graph
- 2) Technical Data Sheet
- 3) Turbocompressor Control Schematic
- 4) Communication with Master Control Unit Options (if provided)
- 5) Typical Sulzer Turbocompressor HST layout drawing
- 6) Compressor Test Code Comparison
- 7) Warranty

HST™ Turbocompressor *

Sulzer Pumps Solutions Inc. ("Manufacturer") warrants the above referenced Sulzer brand equipment ("Products"):

- i) will be of the kind and quality as described in the contract, and
- ii) will be free of material defects in workmanship and material, and
- iii) will, to the extent required for its functioning, be free from defects in design. However, Manufacturer shall not be held responsible for (i) selection or choice of products for a general or specific use, including quantities or sizing of products; or (ii) the design of the Products (including the selection of the materials) if the design and/or the selection of the materials was not chosen or provided by Manufacturer.

The warranty shall begin upon the delivery of the Products and expire on the earliest of the below dates ("Warranty Period"):

- i) twenty-four (24) months from date of installation of the Products; or
- ii) thirty (30) months from the date the Manufacturer made the relevant Products available for delivery.

This warranty is contingent upon start-up of the Products on site by an authorized Manufacturer's representative, as verified by receipt of start-up reports completed and signed by an authorized Manufacturer's representative, as well as any other documentation required by Manufacturer to support the claim.

In the event that Manufacturer undertakes any repair or replacement of any Products or parts thereof in accordance with its obligations under this warranty, such repaired or replaced part shall be warranted in accordance with this warranty for a period of ninety (90) days from the date of completion thereof or until the end of the Warranty Period, whichever expires later. Such extended Warranty Period shall under no circumstances exceed a period of ninety (90) days after the end of the original Warranty Period.

If during the Warranty Period, any Products or parts thereof fail to meet the requirements set out in this warranty, the purchaser or end user shall immediately provide written notification to Manufacturer stating the reasons therefor. Upon receipt of prior written authorization from Manufacturer, Products shall be transported to Manufacturer's authorized service center, prepaid, at purchaser or end-user's cost. Manufacturer's sole obligation shall be to repair, modify, or replace the affected product(s) or part(s) thereof at Manufacturer's sole option. Manufacturer shall be liable for Manufacturer's own costs incurred as a result of such action only. In no event shall Manufacturer be responsible for the cost of providing access to the Products or parts thereof, or costs of disassembly, removal or reinstallation of any Products or parts thereof. Product(s) or part(s) thereof repaired or replaced under this warranty will be returned with freight prepaid. Products must be repaired by an authorized Manufacturer repair center for warranty coverage to be considered. Explosion-proof or other agency approved Products must be repaired at a Manufacturer's authorized service center in order to retain the agency's approval rating.

This warranty shall not apply and shall terminate immediately if the faults or defects referred to herein cannot be proved to be a result of Manufacturer's failure under this warranty. Such exclusions from warranty shall include, but not be limited to, any Products or parts thereof which have been (i) subjected to misuse, misapplication, accident, alteration, neglect, failure to act in a timely manner to address alarms/warnings, or physical damage; (ii) stored outside and/or in a non-climate controlled environment, installed, operated, and/or maintained in a manner which is contrary to Manufacturer's written instructions as it pertains to installation, operation and maintenance of the Products, including but without limitation to being operated without being connected to monitoring devices supplied with specific products for protection; (iii) used in an application or for pumping liquids other than the use for which it is intended as specified in Manufacturer's product literature; (iv) damaged due to a defective power supply, improper electrical protection, faulty repair, ordinary wear and tear, corrosion, erosion or chemical attack, an act of God, an act of war or by an act of terrorism; (v) damaged resulting from the use of accessory equipment not sold by Manufacturer or not approved by Manufacturer for use in connection with Manufacturer's products; or (vi) repaired or altered without Manufacturer's written consent.

This warranty does not cover costs for standard and/or scheduled maintenance that is performed, nor does it cover Manufacturer's parts that, by virtue of their operation, require replacement through normal wear (aka: Wear Parts), unless a defect in material or workmanship is determined by Manufacturer. Wear Parts are defined as air filters, batteries, VFD, and MBC cooling fans and/or any items deemed necessary to perform and meet the requirements of normal maintenance on all Manufacturer's equipment.

All protection features (such as fuses, motor and VFD over temperature, over pressure, shaft position, etc.) incorporated in the Products must be properly connected to Manufacturer supplied or approved monitoring device(s) for warranty coverage. This warranty is valid only if alarm monitoring components, cables, and/or control components/panels supplied or authorized by Manufacturer are used. If protection feature(s) is(are) not connected, for any reason, it must be approved, in writing, by the Manufacturer, to validate the warranty coverage.

Manufacturer shall not be liable for any special, indirect, consequential, incidental, or punitive damages, or profit loss of any kind. Unless authorized in writing by Manufacturer, Manufacturer shall not be responsible for damages for delay or expenses for rented (replacement) equipment, pump removal, installation, contractors, or repairs.

This warranty shall extend only to the initial end user.

CORRECTION OF NONCONFORMITIES IN THE MANNER AND FOR THE PERIOD OF TIME PROVIDED WITHIN THIS WARRANTY SHALL CONSTITUTE FULFILLMENT OF ALL LIABILITIES OF MANUFACTURER TO PURCHASER WHETHER BASED ON CONTRACT, NEGLIGENCE, OR OTHERWISE, WITH RESPECT TO THE PRODUCTS AND PARTS THEREOF, INCLUDING ANY SERVICES PERFORMED. MANUFACTURER MAKES NO OTHER WARRANTY, GUARANTEE, OR REPRESENTATION IN RESPECT OF THE PRODUCTS AND PARTS THEREOF, INCLUDING ANY SERVICES PERFORMED OTHER THAN AS SPECIFIED IN THIS WARRANTY. ALL OTHER WARRANTIES, CONDITIONS, AND REPRESENTATIONS, EXPRESSED OR IMPLIED BY STATUTE, COMMON LAW, OR OTHERWISE, IN RELATION TO THE SUPPLY OF THE PRODUCTS, INCLUDING BUT NOT LIMITED TO THE IMPLIED WARRANTIES OR MERCHANTABILITY AND FITNESS FOR A PARTICULAR PURPOSE, ARE EXCLUDED TO THE EXTENT PERMITTED BY LAW.

* This warranty is applicable to Products supplied by Sulzer Pumps Solutions Inc. or Sulzer Pumps (Canada) Inc. for installation in the U.S.A. or Canada, unless specifically indicated otherwise in writing by Manufacturer.

TECHNICAL INFORMATION

Sulzer TURBOCOMPRESSOR HST

Sedalia, MO
Southeast Wastewater Treatment Plant

1 DESIGN DATA

1.1 Application

Municipal Wastewater Treatment Plant

1.2 Site Conditions

- Gas to be handled¹ - air
- Altitude - 801 ft
- Atmospheric pressure - 14.28 psia
- Inlet pressure losses - 0.06 psi
- Inlet pressure - 14.22 psia (into blower package)
- Ambient temp. range - 0°F to 105°F
- Process air inlet temp. range - 0°F to 105°F
- Relative humidity range - 36 to 90% non-Condensing

1.3 Operating Conditions and Assumptions

- Discharge pressure - 7.0 psig
- Total Air flow required² - 3,408 SCFM (1,704 SCFM per blower)

1.4 Power Supply

- 480 V / 3 Ph / 60 Hz

Note:

1 - See Technical Specification Sheet for air quality.

2 - Air @ 68°F, RH 36%, 14.7 psi a

2 Technical Solution

2.1 Selection

In order to meet the specified conditions, Sulzer offers a complete compressor system consisting of Two (2) Model HST 2500-U100-1-L-48 Turbocompressors, each with a motor rated for 100 Input HP, in a Two (2) operating plus Zero (0) standby configuration plus accessories.

See the graph in the appendix for compressor performance data.

A Master Control Unit will control the above compressor system to ensure operation within the best efficiency range.

2.2 Overview

The Sulzer Turbocompressor HST is a completely factory tested unit delivered ready to install blower that provides air to your process in a highly efficient manner. It is a single stage radial centrifugal compressor that delivers completely **oil free air** to the process and offers both individual and system **power optimization** under all duty conditions including inlet air temperature and differential pressure changes.

The turbocompressor has a simple design comprising a radial centrifugal impeller driven by a high-speed electric motor through a frequency inverter. **The rotor is supported on oil free magnetic bearing system levitates the shaft providing** non-contact, non-wear, frictionless performance. The inverter and magnetic bearing controller are housed in an **integrated control cabinet** that features a main power disconnect, local control keypad with stop, start, local, remote push buttons and display panel. An automatic blow off valve is also included in the assembly. A **high efficiency acoustic enclosure** surrounds the compressor/motor assembly area minimizing blower room noise. All of the above items are **mounted on a common small footprint base plate** (often 33% smaller than other blowers) that can be easily moved with a forklift.

These turbocompressors offer modern, **state of the art technology, high efficiency** encompassing features designed to providing both the installer and user with the maximum benefits available. They are a departure from the conventional type of compressor, many of which rely on basic designs and principles that have not changed for many years. The machines are manufactured in full compliance with all relevant EU Norms and Directives for Machinery, Low Voltage, and Electromagnetic Compatibility as well as all relevant UK Health & Safety legislation.

2.3 Features & Benefits

- The HST will **operate in the best efficiency area down to 50% of the maximum flow.**
- Each HST is a totally integral, single stage, turbocompressor that needs **no additional requirement for external inverter drives, soft starters, instrumentation or control panels.** The additional cost of these items should be considered when comparing the capital cost of the HST with other compressors.
- Each HST has an internal frequency inverter, which allows the compressor to **automatically match compressor performance exactly to the process demand.** The compressor even compensates for variations in ambient pressure and temperature conditions thereby constantly optimising energy consumption under all conditions.
- Each HST has a Cutler-Hammer (Vacon) NX series VFD with an interface keypad that controls and monitors the turbocompressors performance.
- Each HST is complete with its own **high efficient acoustic enclosure** that keeps the noise level below the value shown in the appendix without inlet or outlet silencers 3 feet from the compressor at the worst-case conditions described below.
 - The compressor is running at maximum pressure
 - The compressor is running at maximum speed

In service the noise level will be reduced if the compressor is running at a more efficient point however the configuration of the compressor building and discharge pipe work arrangement etc. will also contribute to the overall site noise levels experienced. It is for this reason that we cannot at this stage make firm noise level guarantees under site conditions.

It is possible to lower noise levels even further by wrapping and supporting all piping. Another way to reduce noise even more is by installing a special forced compressor ventilation however this last option is complicated and very expensive and should only be considered in the absence of any other alternative.

- The HST is designed to minimise the footprint required for installation. In some cases, the HST is **one-third the size of comparable compressors or blowers** thus allowing them to be housed in a much smaller building lowering construction costs.
- The HST provides a **vibration and pulse free operation** due to its revolutionary magnetic bearing design eliminates the need for extremely thick foundations or plinths **reducing construction costs.** The machines are installed quickly and easily onto a 6-inch-thick concrete floor. **Pulsation free air** also assists the aeration process by allowing the production of a constant supply of fine bubbles instead of a mix of fine and coarser bubbles increasing the oxygen transfer in the process.
- The HST is **light and is easy to move.** It can be transported on a conventional pallet truck or forklift. There is no need for overhead lifting cranes or gantries.

- The Sulzer Turbocompressor HST requires *virtually no maintenance which reduces maintenance costs by as much as 85 to 90%*. It has only *one moving part*, the rotor. The active magnetic bearing system ensures that there is *no mechanical contact at any time with any parts eliminating wearing parts that will need to be replaced*. The internal frequency converter replaces gearboxes, which historically are a source of high maintenance costs. The frequency inverter also provides control of the output hence there are no complex guide vane mechanisms, which require periodic compressor shutdown for routine cleaning to keep other single stage compressors operating at peak efficiency. The elimination of oil and other fluids in the compressor system makes the Sulzer Turbocompressor HST a clean and simple compressor to maintain (process & cooling air filters need to be changed). The need for heating, cooling, circulating, filtering and disposal of the fluids needed for other compressor systems increases power usage and the associated routine maintenance costs are eliminated with the HST. In addition, fluid disposal costs are also eliminated. The only maintenance task needed to keep the HST compressor operating at peak efficiency throughout its lifetime is to change the cooling and process air filter elements when required. On average this is once per year depending on site conditions and takes less than 20 minutes.
- Because of its non-contacting operation, the HST has *no wearing parts*. Therefore, it is possible to *maintain the "as manufactured" performance* quoted throughout the life of the compressor without the expensive maintenance and rebuilds needed with other blowers. It is unlikely that our competitors can maintain this "as manufactured condition" of their compressors without continual, expensive and extensive maintenance. This will inevitably lead to a loss in performance efficiency and an increase in operating costs of our competitors' compressor.
- Each HST is a completely integrated compressor with Cutler-Hammer (Vacon) VFD speed control and keypad interface is included as standard that *provides soft starting, power factor correction, self-diagnostic and continuous monitoring of its operation*.
- Each HST is supplied with an *uninterruptible power supply* (UPS) system that provides a secondary source of power for the magnetic bearings and magnetic bearing controller. This system is a back up to the power generation mode feature that is the first line of safety if a power outage occurs to assure that the turbocompressor will spin down without damaging the high-speed unit.
- Each Sulzer Turbocompressor HST is supplied with a modem for remote monitoring of the MBC.

2.4 Compressor Performance

The performance graph shows the typical compressor performance for each compressor being offered at the conditions stated on the Design Data Sheet.

We should stress that any comparison with alternative offers must be made using identical parameters and include all power demands such as oil circulators, oil heaters and acoustic enclosure ventilation fans etc.

3 Exclusions and Assumptions

3.1 Assumptions

- Reasonable access to the site and working area to enable continuous installation.
- Free access to facilities
- The compressors are to be installed in a compressor room constructed by others
- The compressor room floor will be flat and level to standard civil tolerances
- That the Sulzer Turbocompressor HST can be off loaded and placed directly into the compressor building by others.
- Cable tray or ducts to each compressor for the communications cabling will be supplied and installed by others.
- Please note that the power grounding wire needs a minimum size per our Installation and Maintenance Instructions. Power Wiring needs to be sized per NEC and local codes.
- Please note that a Pressure Differential Switch needs to be installed on the Inlet Filters and wired back to the HST Blower Enclosure Control Terminal.

3.2 Exclusions

Each Sulzer Turbocompressor HST is offered with the following items excluded from the quoted price.

- Supply and installation of interconnecting communications cabling between each turbocompressor and the Plant Control System.
- Installation of compressor units, accessories and associated pipe work
- Supply and installation of electrical power and signal cables to each turbocompressor and the Master Control Unit.
- Provision of any further instrumentation other than that contained within each turbocompressor or the Master Control Unit. This also excludes the pressure or D.O. transducer required to generate the 4-20ma signal for compressor control.
- Pipe insulation as deemed necessary by the client to prevent contact with hot pipes.
- The accessories include the items as shown on the typical HST Integral Turbocompressor layout drawings in the appendix. The final design of the installation may necessitate the removal or addition of items as appropriate.
- **FTC Equipment will install and make all connections necessary.**

SULZER ABS TURBOCOMPRESSOR HST

APPENDIX

**High Turbocompressor HST
Performance**



Date: 31-Jul-24

Quote No.: 2024-Q062-R2

HST 2500-U100-1-L-48

Project Name: **Sedalia SE WWTP**

Total Design Air Flow: **3,408 SCFM**
 Air Flow Per Blower: **1,704 SCFM**
 Air Flow Range Per Blower³: **730 - 2,050 SCFM**

Total Blowers: **2**
 Operating Blowers: **2**
 Spare Blowers: **0**

Maximum Input Power: **100 HP**
 Electric Power: **480 / 3 / 60**
 Maximum Motor Speed: **32,100 RPM**

Altitude: **801 ft**
 Atmospheric Pressure: **14.28 psia**

Operating Pressure Ratio: **1.50**
 Operating Pressure Ratio Limit: **1.67**

Inlet Losses: **0.06 psia**
 Blower Intake Pressure: **14.22 psia**

Max Discharge Temp: **207° F**

Differential Pressure: **7.00 psig**
 Absolute Discharge Pressure: **21.28 psia**

- 105° F 90% RH
- 32° F 50% RH
- 68° F 36% RH
- 0° F 50% RH
- 1,704 SCFM Duty Point

Blower Performance

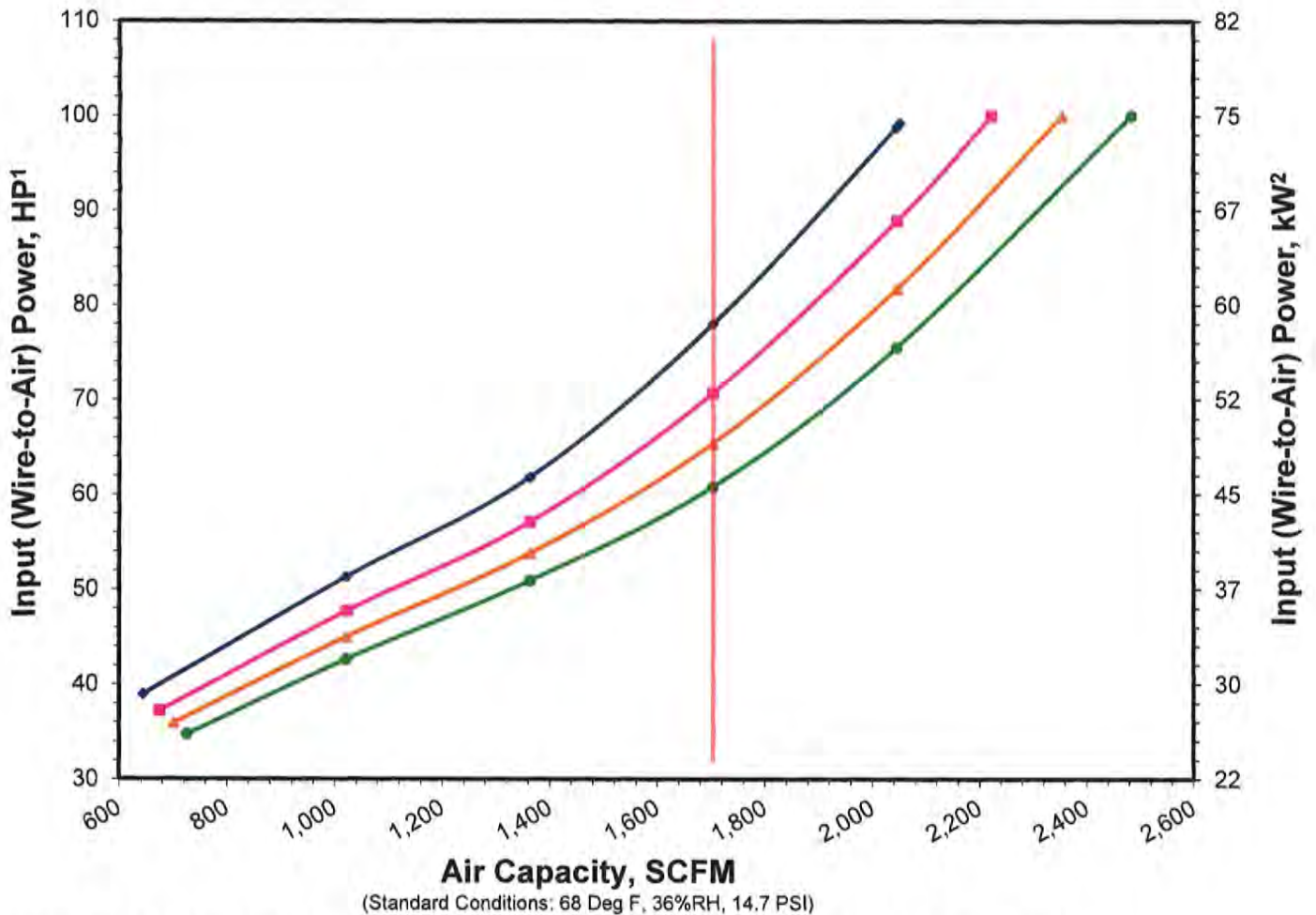

- 1) Please note that the input (wire to air) power includes all electromechanical losses associated with the VFD, Motor, Impeller, etc. This value does NOT represent motor shaft/break horsepower (BHP) as is typically published for standard NEMA motors.
- 2) kW input power rounded to nearest whole number.
- 3) The approximate maximum airflow at the highest temperature and the approximate minimum airflow at the lowest temperature. Minimum and maximum flow will be lower at higher operating temperature and higher at lower temperatures.

HST™ 2500 Turbocompressor

SULZER

A highly efficient and reliable single-stage centrifugal compressor for the provision of oil-free, low-pressure air.

Construction

High-speed electric motor

A vertically mounted high-frequency electric motor for variable speed operation. The motor is air-cooled by an integrated shaft mounted fan and the windings are protected by Pt100-sensors monitored by the local control system.

Air end

The impeller has been designed to optimize performance and is machined from a solid piece of high-strength aluminum alloy. The volute and other main components are made from cast aluminum. A non-contact seal between air-end and motor minimizes losses to maintain high efficiency.

Variable frequency drive

Flow control is provided by a built-in variable frequency drive which also accommodates variations in outlet pressure and ambient inlet conditions. The variable frequency drive's soft-start facility eliminates peak starting currents.

Active magnetic bearings

Two radial bearings and two axial bearings support the rotor. The magnetic bearing controller uses data provided by multiple sensors to continuously manage the position of the rotor.

Blow-off valve

The blow-off valve is mounted on the compressor assembly with attenuation provided by an external silencer.

Acoustic enclosure

The enclosure provides protection for the electrical and mechanical components and provides efficient noise attenuation for the machine. The enclosure is constructed from zinc-plated steel. It is suitable for indoor use (IP33D / NEMA 2).



Compressor Control

Local control

The built-in local Human-Machine-Interface (HMI) provides control and monitoring for the safe and efficient operation of the machine. Flow may be controlled directly by the operator, or alternatively, the turbocompressor can follow a given reference value. The local HMI uses a keypad and text display to provide access to the operator.

Connections

Analog and digital control and monitoring connections are built in. Fieldbus connections such as Profibus, Profinet, Modbus RTU, Modbus TCP, and EtherNet/IP are available as options.

Remote connections

A secure connection facilitating service and monitoring can be ordered as an option.

Options

Various options for handling special requirements regarding e.g., temperature, dusty environments and locations with high moisture can be selected.

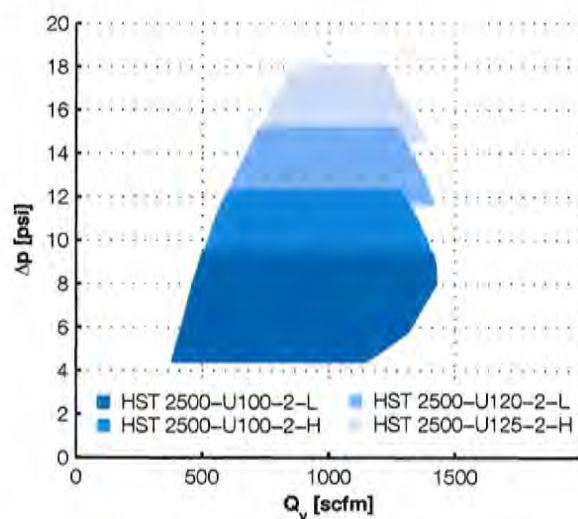
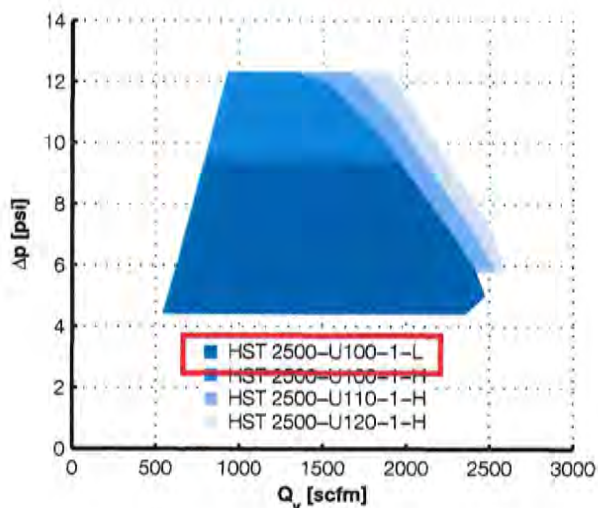

Accessories

Required accessories for installation such as flexible joints, valves, silencers, and air filters are available from Sulzer.

Performance Testing

Compressor performance tests are performed on every machine manufactured and certificates issued to confirm compliance. The tests are carried out at the Sulzer factory test facility. Performance is guaranteed with a manufacturing tolerance of $\pm 2\%$ and a measurement tolerance according to ISO 5389. Optionally tests can be performed according to ISO 5389 or ASME PTC 10. The test can be witnessed by the customer or a third party inspector.

Certification and Standards

The compressor is certified according to the relevant UL and CSA standards:

- UL 1450
- CSA C22.2 No. 68

The product is designed and manufactured in accordance with EN 61800-3 standard and intended for use in second environment locations, e.g., in industrial areas.

Installation Conditions ⁽¹⁾

| Altitude | |
|--|--|
| Maximum altitude | 8200 ft above sea level ⁽²⁾ |
| Air quality | |
| Permitted chemical vapors | IEC 60721-3-3 class 3C3 |
| Ambient conditions | |
| Ambient temperature range | Min. 14 °F, max. +113 °F |
| Ambient relative humidity | < 95 %, non-condensing, non-corrosive, no dripping water |
| Inlet conditions | |
| Air temperature range for ducted process air inlet | Min. -22 °F, max. +122 °F |

⁽¹⁾ Sulzer may approve applications outside these criteria.

⁽²⁾ 6560 ft above sea level for 580 V compressors.

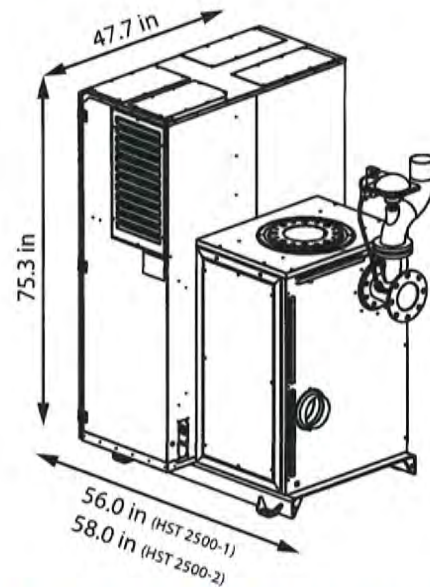

Compressor Data

| | HST 2500- | U100-1-L / H | U110-1-L / H | U120-1-L / H | U100-2-L / H | U120-2-L / H | U125-2-L / H |
|----------------------------|---------------------------------------|------------------------------|-------------------|-------------------|-------------------|-------------------|-------------------|
| Air flow range [scfm] | L | 550-2400 | 550-2500 | 550-2600 | 400-1400 | 600-1450 | 600-1450 |
| | H | 350-2400 | 650-2500 | 650-2600 | 450-1400 | 750-1400 | 700-1300 |
| Pressure rise [psi] | L | 4.4-9.4 | 4.4-9.4 | 4.4-9.4 | 4.4-9.4 | 11.6-15.2 | 11.6-15.2 |
| | H | 5.8-18.8 | 5.8-12.3 | 5.8-12.3 | 5.8-12.3 | 14.5-18.1 | 14.5-18.1 |
| Noise level [dB] | L | 66 ⁽³⁾ | 66 ⁽³⁾ | 66 ⁽³⁾ | 72 ⁽³⁾ | 74 ⁽³⁾ | 74 ⁽³⁾ |
| | H | 69 ⁽³⁾ | 69 ⁽³⁾ | 69 ⁽³⁾ | 72 ⁽³⁾ | 72 ⁽³⁾ | 72 ⁽³⁾ |
| Input power [hp] | | 100 | 110 | 120 | 100 | 120 | 125 |
| Power supply [V] | | 460-600 | 460-500 | 460-500 | 460-600 | 460-500 | 460-500 |
| Input power frequency [Hz] | | 50/60 | 50/60 | 50/60 | 50/60 | 50/60 | 50/60 |
| 480 V | Max. input current [A] ⁽³⁾ | 97 | 107 | 117 | 97 | 117 | 122 |
| | Cable size [AWG or MCM] | 3x1/0+3 | 3x1/0+3 | 3x1/0+3 | 3x1/0+3 | 3x1/0+3 | 3x1/0+3 |
| | Fuse size [A] | 100 | 125 | 125 | 100 | 125 | 125 |
| 580 V | Max. input current [A] ⁽³⁾ | 80 | | | 80 | | |
| | Cable size [AWG or MCM] | 3x1/0+3 | not available | not available | 3x1/0+3 | not available | not available |
| | Fuse size [A] | 100 | | | 100 | | |
| Auxiliary current [A] | | 10 | 10 | 10 | 10 | 10 | 10 |
| Auxiliary supply [V] | | 360-550 | 360-550 | 360-550 | 360-550 | 360-550 | 360-550 |
| Weight [lb] | | 1800 | 1800 | 1800 | 1800 | 1800 | 1800 |

⁽³⁾ The maximum input current is calculated using the nominal voltage. The cable and fuse sizes are recommendations and based on the supply current and cables rated to 158 °F.

⁽⁴⁾ The noise values are presented with Outlet Cone Insulation (accessory OCI).

⁽⁵⁾ The noise values are presented without Outlet Cone Insulation (accessory OCI).

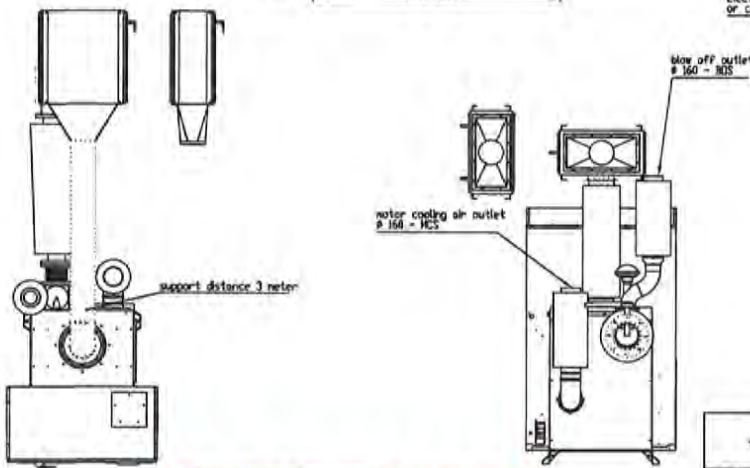
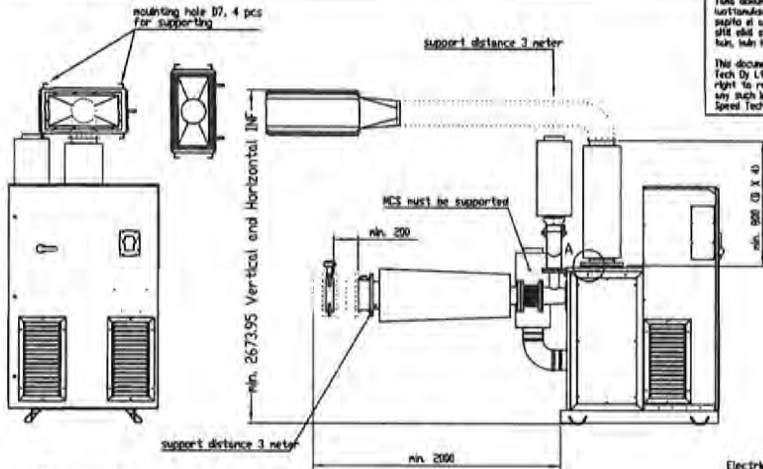

Tämä dokumentti sisältää High Speed Tech Oy:ltä omistaneen luottamuksellista tietoa. Dokumentin vastaanotto ja hallussapito ei suoraan luovuta, myyntiä tai julkistusta siitä eikä sen sisältöä muuta, luottamuksellista tai muuta, kuin High Speed Tech Oy:ltä kirjallisella luvalla.

This document contains proprietary information of High Speed Tech Oy Ltd. Neither receipt or possession thereof confers any right to reproduction, or use, or disclosure, in whole or in part, any such information without written authorization from High Speed Tech Oy Ltd.

| Rev | Change | By | Date | Reason |
|-----|--------|----|------|--------|
| 1 | | | | |
| 2 | | | | |
| 3 | | | | |
| 4 | | | | |
| 5 | | | | |
| 6 | | | | |
| 7 | | | | |
| 8 | | | | |
| 9 | | | | |
| 10 | | | | |
| 11 | | | | |
| 12 | | | | |
| 13 | | | | |
| 14 | | | | |
| 15 | | | | |
| 16 | | | | |
| 17 | | | | |
| 18 | | | | |
| 19 | | | | |
| 20 | | | | |

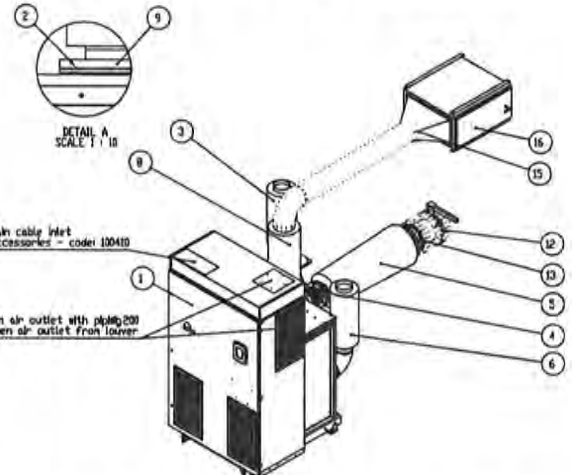

Electric cabin air outlet with p44q200 or closed when air outlet from lower

| Rev | Change | By | Date | Reason |
|-----|--------|----|------|-------------------------------------|
| 15 | 1 | | | Horizontal Inlet Filter - SF 250 |
| 15 | 1 | | | Inlet Filter Adapter - SF 250 |
| 13 | 1 | | | Back face barrier - BF 250 |
| 12 | 1 | | | Bullet panel valve - BV 250 |
| 7 | 1 | | | Inlet collar flange - CF 250 |
| 6 | 1 | | | Inlet slencer - IS 250 |
| 6 | 1 | | | Motor cooling air slencer - MCS 250 |
| 5 | 1 | | | Bullet cone slencer - CS 250 |
| 4 | 1 | | | Bullet flexible joint HET SF J 250 |
| 3 | 1 | | | Base Off Slencer 250 |
| 2 | 1 | | | Inlet screw trap - IT 250 |
| 1 | 1 | | | V-2500-1-L and FH |

Layout Example Only

| | | | |
|--|------------------------------|-------------------------------|-----------------------|
| HST HIGH SPEED TECH CAD | Drawing Scale 1:30 | Date 17.5.2005 | Rev RA |
| | Order No. HST S2500-1 INF | Project No. HST 2500-1-A-5 | Drawing No. 100674 |

Turbocompressor HST Control Schematic

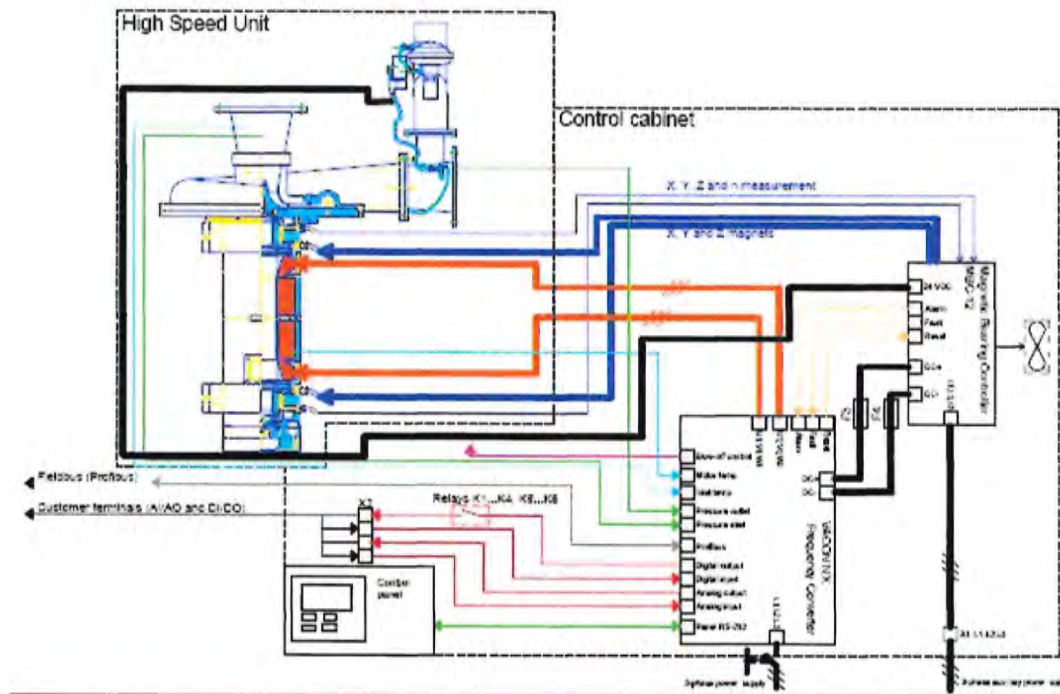

CONNECTIONS

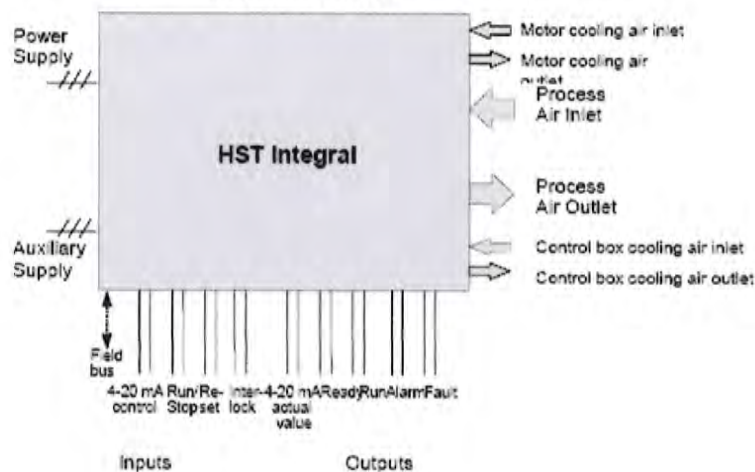

Turbocompressor HST Modular Control Unit Communication Options

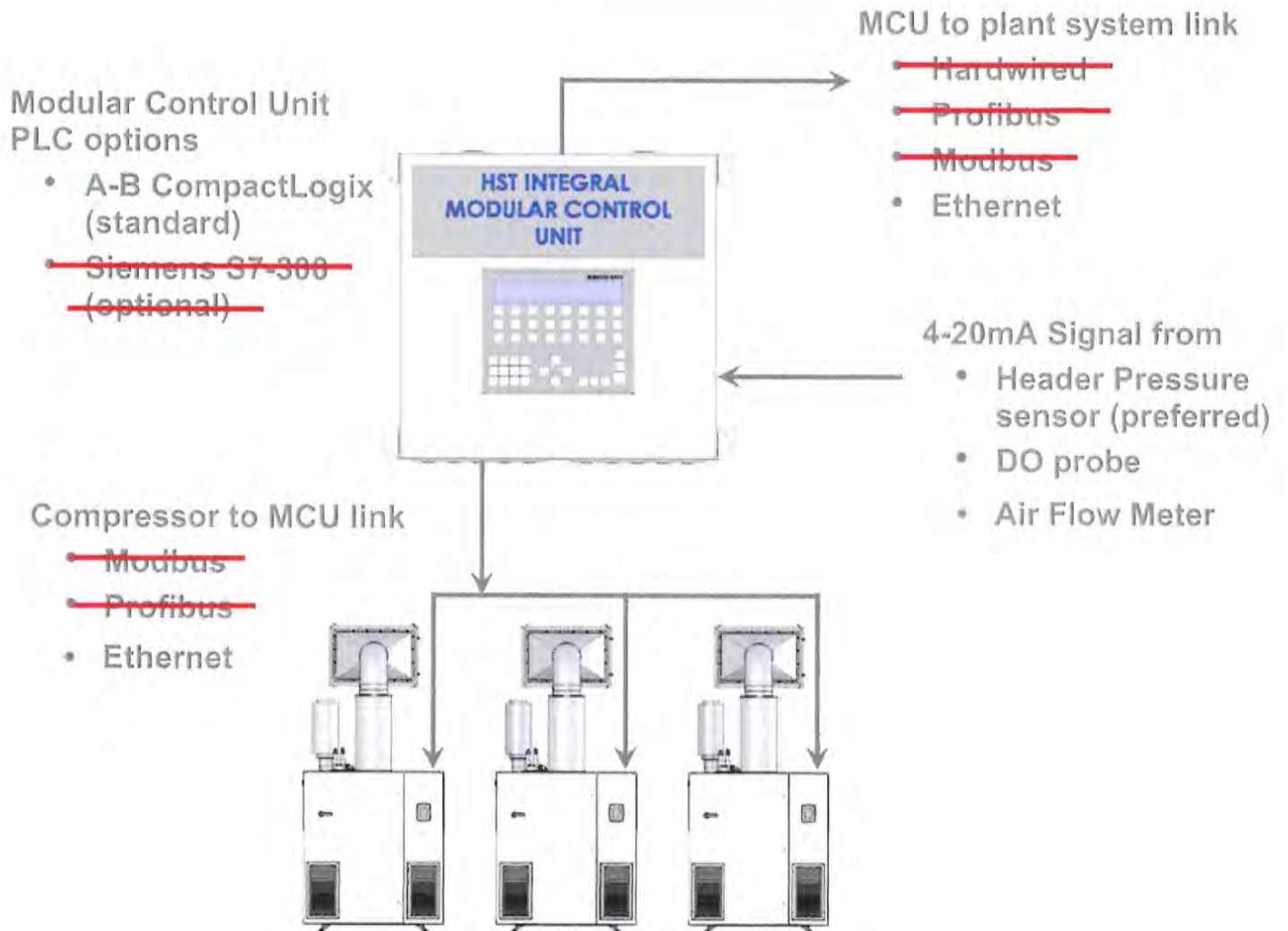

Use with three or more turbocompressors



November 3, 2004

HIGH SPEED COMPRESSOR TEST CODES

The high speed compressors developed by High Speed Tech Oy Ltd have been tested at Laboratory of Fluid Dynamics at Lappeenranta University of Technology and at HST Lappeenranta factory, where similar test loop facilities have been built.

There are no standard test codes applicable for integrated high speed compressors. Therefore, the test following test codes have been applied

- ISO 5389:1992 Turbocompressors
- VDI 2045:1993 Acceptance and Performance Tests on Turbo Compressors and Displacement Compressors
- ASME PTC 10 – 1974 / Reaffirmed 1986 Compressors and Exhausters

Main difference is the compact integration of the compressor and motor. As they can not be separated, the measurement of only the compressor shaft power is not possible and therefore unnecessary to follow within the various test codes.

The main quantities measured and investigated in the tests are:

- overall electric power
- pressure ratio of the compressor
- the capacity of the compressor

Power

The standards put a strong emphasis on the thermal equilibrium of the turbo compressor. The long measurement tests at LUT have shown that the overall power (which power is solely used in declaring the HST performance) reaches quickly a constant level, while the power balance between the motor and the drive (compressor) takes much longer time to be correctly measured (for example ASME PTC 10 requires minimum of 30 minutes between points).

The HST measurement routine allows a longer start time for the first measurement, but the following test points are reached within minutes. The measurement software informs the personnel as an adequate measurement point is achieved and a new valve position can be chosen.

Pressure ratio

The pressures are measured in the pressure measuring stations before and after the compressor. The locations of the four static taps, the distances of flow straightening and the method of the measurements are performed as defined in both PTC 10 and ISO 5389.

The capacity of the compressor

ISO 5389 states that the flow measurements are done according to ISO 5167, which acknowledges both the long radius and ISA 1932 nozzles. By comparison, the uncertainty coefficient of the ISA 1932 is lower than the long radius nozzle. The use of ISA 1932 at the inlet of the compressor enables us to make the flow measurements in almost constant conditions and improves further the reliability of the measurements.

The ASME PTC 10 includes only the long radius nozzle, but states that under bilateral agreements, the interested parties can agree upon the type of metering device suited for the conditions and the





LAPPEENRANTA
UNIVERSITY OF TECHNOLOGY

choice shall be stated in the test report. As the chosen device is ISA 1932 mentioned in the international standard, it is our understanding that ISA 1932 also fulfils the requirements of PTC 10.

The flow is measured in the inlet conditions and the only leakage of the machine is through a multi knife radial labyrinth seal between the base of the impeller and compressor base. Due to relative small pressure difference, this leakage is less than 1% and very difficult to measure. The ISO 5389 states that in these circumstances appropriate corrections shall be agreed between the manufacturer and purchaser. PTC 10 states that the capacity is the net rate of flow compressed and delivered. The HST margin covers this difference in measurements.

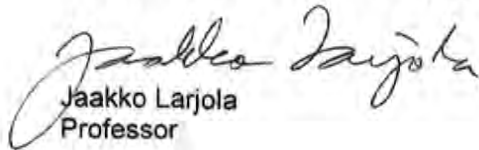
In Lappeenranta, November 3, 2004

Jaakko Larjola
Professor

Jari Backman
Professor

BILL NO. _____

ORDINANCE NO. _____

AN ORDINANCE AMENDING SECTION 50-50 OF THE CODE OF ORDINANCES OF THE CITY OF SEDALIA, MISSOURI RELATING TO THE DENIAL OF AN APPLICATION FOR A RIGHT-OF-WAY PERMIT.

WHEREAS, the City of Sedalia, Missouri has the authority to enact regulations regarding the issuance and denial of licenses and permits; and

WHEREAS, the City of Sedalia, Missouri has determined that it is appropriate and necessary to amend Section 50-50 of the City's Code of Ordinances in order to adopt new regulations relating to the denial of licenses and permits for placement of wireless facilities and utilities in the City's Right-of-Way; and

WHEREAS, the City of Sedalia, Missouri has determined that it has the authority to manage the use of its public Right-of-Way.

NOW THEREFORE, BE IT ORDAINED BY THE COUNCIL OF THE CITY OF SEDALIA, MISSOURI as follows:

Section 1. Chapter 50, Article III, Section 50-50 related to the Denial Of An Application For A Right-Of- Way Permit is hereby amended to read as follows:

"Sec. 50-50. - Denial of an application for a right-of-way permit, when—Revocation of a permit, when—Action for review by court.

- (a) The city may deny an application for a right-of-way permit, if denial is deemed to be in the public interest. In determining whether a denial is in the public interest, the City may consider all relevant factors including but not limited to:
 - (1) Failure to provide a complete application. The right-of-way user failed to provide all the necessary information requested by the city for managing the public right-of-way.
 - (2) The right-of-way user has failed to return the public right-of-way to its previous condition under a previous permit or after prior excavations by the applicant or right-of-way user.
 - (3) The right-of-way user has delinquent fees, costs, or expenses owed to the city from a previous permit.
 - (4) The extent to which the right-of-way space where the permit is sought is available; relevant factors for the availability of right-of-way space include but are not limited to:
 - a. Whether the applicant's placement of their equipment, facilities, or structures would overwhelm the immediate area rendering it out of scale with adjacent structures, plantings, landscaping, and already existing uses of the right-of-way;

- b. The competing demands for the particular space in the right-of-way;
 - c. The applicability of any ordinance or other regulations, including City zoning regulations, that affect the location of or other standards for facilities in the right-of-way.
 - d. The placement of above ground facilities, structures, or equipment that would result in less than seventy-five (75) linear feet distance between other existing or new above ground facilities.
 - e. The placement of facilities, structures, or equipment that are flush with the ground, that would result in less than seventy-five (75) linear feet distance between other existing or new above ground or flush with the ground facilities, structures, or equipment.
- (5) Placement of equipment, facilities, or structures in a right-of-way that are more than ten (10) feet from a property line. If it is impractical to place equipment, facilities, or structures within ten (10) feet of a property line, at the City's discretion, a permit for placement of equipment, facilities, or structures more than ten (10) feet from a property line in a right-of-way may be issued if the right-of-way user provides adequate landscaping that conforms with the surrounding aesthetics of the property.
 - (6) Placement of equipment, facilities, or structures outside the City's right-of-way.
 - (7) Refusal to comply with alternative right-of-way work methods, locations, or other reasonable conditions required by the director of public works or his/her representative.
 - (8) The city has provided the right-of-way user with a reasonable, competitively neutral, and nondiscriminatory justification for requiring an alternative method for performing the work identified in the permit application or a reasonable alternative route that will result in neither additional installation expense up to ten percent to the right-of-way user nor a declination of service quality;
 - (9) The city determines that denial is necessary to protect the public health and safety, provided that the authority of the city does not extend to those items under the jurisdiction of the public service commission, such denial shall not interfere with a public utility's right of eminent domain of private property, and such denials shall only be imposed on a competitively neutral and nondiscriminatory basis; or
 - (10) The area is environmentally sensitive as defined by state statute or federal law or is a historic district or culturally sensitive area as defined by applicable federal, state, or local laws.
- (b) The city may, after reasonable written notice and an opportunity to cure not longer than 30 days, which cure period may be immediate if certain activities must be stopped to be

protective of public safety or health, revoke a right-of-way permit granted to a right-of-way user, with or without fee refund. The cure period shall be extended by the director of public works on good cause shown by the right-of-way user. The city may impose a penalty as established by the city until the breach is cured, but only in the event of a substantial breach of the terms and material conditions of the permit. A substantial breach by a permittee includes but is not limited to:

- (1) A material violation of a provision of the right-of-way permit or this article;
 - (2) An evasion or attempt to evade any material provision of the right-of-way permit, or the perpetration or attempt to perpetrate any fraud or deceit upon the city or its citizens;
 - (3) A material misrepresentation of fact in the right-of-way permit application;
 - (4) A failure to complete work by the date specified in the right-of-way permit, unless a permit extension is obtained or unless the failure to complete the work is due to reasons beyond the permittee's control; and
 - (5) A failure to correct, within the time specified by the city, work that does not conform to applicable national safety codes, industry construction standards, this article, or local safety codes that are no more stringent than national safety codes, upon inspection and notification by the city of the faulty condition.
- (c) Any breach of the terms and conditions of a right-of-way permit shall also be deemed a violation of this article, and in lieu of revocation the director of public works may initiate prosecution of the right-of-way user for such violation.
- (d) The city shall require right-of-way users to obtain a right-of-way permit, except in an emergency, prior to performing excavation work within a public right-of-way. The city shall promptly, but not longer than 30 days from receipt, process all completed permit applications. If the city fails to act on an application for a right-of-way permit within 30 days, the application shall be deemed approved.
- (e) A right-of-way user that has been denied a right-of-way permit, has had its right-of-way permit revoked, believes that the fees imposed on the public right-of-way user by the city do not conform to the requirements of section 50-54 believes the city has violated any provision of sections 50-45 to 50-55, or asserts any other issues related to the use of the public right-of-way, may bring an action for review in any court of competent jurisdiction in this state.
- (f) Exceptions. Projects with a construction plan approved by the city are not required to obtain a separate right-of-way permit for any work contained in the construction plan approval. City-sponsored capital improvement projects, requiring utility adjustments, are not required to obtain a separate right-of-way permit for any directly associated adjustments or new facilities.”

Section 2. This ordinance shall be in full force and effect from and after its passage and approval.

Section 3. The provisions of any ordinance or code section in conflict with any provision of this ordinance are hereby repealed to the extent of such conflict.

Section 4. The provisions of this ordinance are severable and if any provision hereof is declared invalid, unconstitutional, or unenforceable, such determination shall not affect the validity of the remainder of this ordinance.

Section 5. The City Clerk is hereby authorized to correct any scribes' errors contained herein or made in amending the City Code.

Read two times by title, copies of the proposed ordinance having been made available for public inspection prior to the time the bill is under consideration by the Council and passed by the Council of the City of Sedalia, Missouri this 5th day of August, 2024.

Presiding Officer of the Council

Approved by the Mayor of said City this 5th day of August, 2024.

Andrew L. Dawson, Mayor

ATTEST:

Jason S. Myers
City Clerk

BILL NO. _____

ORDINANCE NO. _____

AN ORDINANCE APPROVING A QUIT CLAIM DEED FOR THE SALE OF PROPERTIES COMMONLY KNOWN AS _____ FROM THE CITY OF SEDALIA, MISSOURI TO _____.

WHEREAS, The City of Sedalia, Missouri has received a proposal from _____ to purchase properties commonly known as _____ for the sum and amount of _____ as contained in the contract for sale of real estate and quit claim deed attached hereto and incorporated by reference.

NOW THEREFORE, BE IT ORDAINED BY THE COUNCIL OF THE CITY OF SEDALIA, MISSOURI, AS FOLLOWS:

Section 1. The Council of the City of Sedalia, Missouri approves and accepts the terms as contained in the contract for sale of real estate in substantially the same form and content as proposed.

Section 2. The Council of the City of Sedalia, Missouri, hereby approves the giving of a quit claim deed by the City of Sedalia, Missouri to _____ for the conveyance of properties commonly known as _____ in substantially the same form and content as proposed.

Section 3. The Mayor or City Administrator are authorized to accept said contract, sign said contract and deed and execute any and all closing documents on behalf of the City of Sedalia, Missouri and the City Clerk is hereby authorized and directed to file in his office the said contract and deed after recording said deed and ordinance with the Pettis County Recorder of Deeds.

Section 4. This ordinance shall be in full force and effect from and after its passage and approval.

Read two times by title, copies of the proposed ordinance having been made available for public inspection prior to the time the bill is under consideration by the Council and passed by the Council of the City of Sedalia, Missouri this 5th day of August, 2024.

Presiding Officer of the Council

Approved by the Mayor of said City this 5th day of August, 2024.

Andrew L. Dawson, Mayor

ATTEST:

Jason S. Myers
City Clerk

BILL NO. _____

ORDINANCE NO. _____

AN ORDINANCE APPROVING A SPECIAL WARRANTY DEED FOR THE SALE OF PROPERTY COMMONLY KNOWN AS _____ FROM THE CITY OF SEDALIA, MISSOURI TO _____.

WHEREAS, The City of Sedalia, Missouri has received a proposal from _____ to purchase property commonly known as _____ for the sum and amount of _____ as contained in the contract for sale of real estate and special warranty deed attached hereto and incorporated by reference.

NOW THEREFORE, BE IT ORDAINED BY THE COUNCIL OF THE CITY OF SEDALIA, MISSOURI, AS FOLLOWS:

Section 1. The Council of the City of Sedalia, Missouri approves and accepts the terms as contained in the contract for sale of real estate in substantially the same form and content as proposed.

Section 2. The Council of the City of Sedalia, Missouri, hereby approves the giving of a special warranty deed by the City of Sedalia, Missouri to _____ for the conveyance of property commonly known as _____ in substantially the same form and content as proposed.

Section 3. The Mayor or City Administrator are authorized to accept said contract, sign said contract and deed and execute any and all closing documents on behalf of the City of Sedalia, Missouri and the City Clerk is hereby authorized and directed to file in his office the said contract and deed after recording said deed and ordinance with the Pettis County Recorder of Deeds.

Section 4. This ordinance shall be in full force and effect from and after its passage and approval.

Read two times by title, copies of the proposed ordinance having been made available for public inspection prior to the time the bill is under consideration by the Council and passed by the Council of the City of Sedalia, Missouri this 5th day of August, 2024.

Presiding Officer of the Council

Approved by the Mayor of said City this 5th day of August, 2024.

Andrew L. Dawson, Mayor

ATTEST:

Jason S. Myers
City Clerk